



# Microtips

---

## TECHNOLOGY

Model No: 13-070XILB0GH1-S

Approved By	

Tel: 1 (888) 499-8477

Fax: (407) 273-0771

E-mail: [mtusainfo@microtipsusa.com](mailto:mtusainfo@microtipsusa.com)

Web: [www.microtipsusa.com](http://www.microtipsusa.com)

## RECORD OF REVISION

Version	Revised Date	Page	Content
V1.0	2016/06/01	--	First Issued
V1.1	2016/11/17	4,15	Update Brightness 600→700cd/m2

## TABLE OF CONTENTS

No.	Content	Page
	TFT Module Specification .....	1
	TABLE OF CONTENTS .....	3
1.	GENERAL DESCRIPTION .....	4
2.	MECHANICAL SPECIFICATION .....	5
3.	PIN DESCRIPTION .....	6
4.	ABSOLUTE MAXIMUM RATINGS .....	7
5.	BLOCK DIAGRAM .....	8
6.	RELATIONSHIP BETWEEN DISPLAYED COLOR AND INPUT .....	9
7.	ELECTRICAL CHARACTERISTICS .....	11
8.	OPTICAL CHARACTERISTICS .....	15
9.	RELIABILITY .....	18
10.	PRECAUTION RELATING PRODUCT HANDLING .....	23

1. GENERAL DESCRIPTION

1.1 Description

The specifications is model 13-070XILB0GH1-S is a color active matrix thin film transistor (TFT) liquid crystal display (LCD) that uses amorphous silicon TFT as a switching device. This model is composed of a TFT LCD panel, a driving circuit, a back light system. This TFT LCD has a 7.0 (16:9) inch diagonally measured active display area with WSGA (1024 horizontal by 600 vertical pixels) resolution.

1.2 Features:

No.	Item	Specification	Unit
1	Panel Size	7.0"	Inch
2	Number of Pixels	1024 (W) x RGB x 600 (H)	Pixels
3	Active Area	154.21 (W) x 85.92 (H)	mm
4	Pixel Pitch	0.1506 (W) x 0.1432 (H)	mm
5	Outline Dimension	164.9 (W) x 100 (H) x 4.6 (T)	mm
6	Number of Colors	262K	- -
7	Display Mode	IPS / Normally Black / Transmissive	- -
8	Viewing Direction	Free direction	- -
9	Display Format	RGB vertical stripe	- -
10	Surface Treatment	Anti-Glare	- -
11	Contrast Ratio	800 (Typ.)	- -
12	Luminance (cd/m <sup>2</sup> )	700 (Typ.)	cd/m <sup>2</sup>
13	Interface	LVDS 6 bit Interface	- -
14	Backlight	White LED	- -
15	Operation Temperature	-20 ~ 70	°C
16	Storage Temperature	-30 ~ 80	°C
17	Weight	TBD	g

## 2. MECHANICAL SPECIFICATION

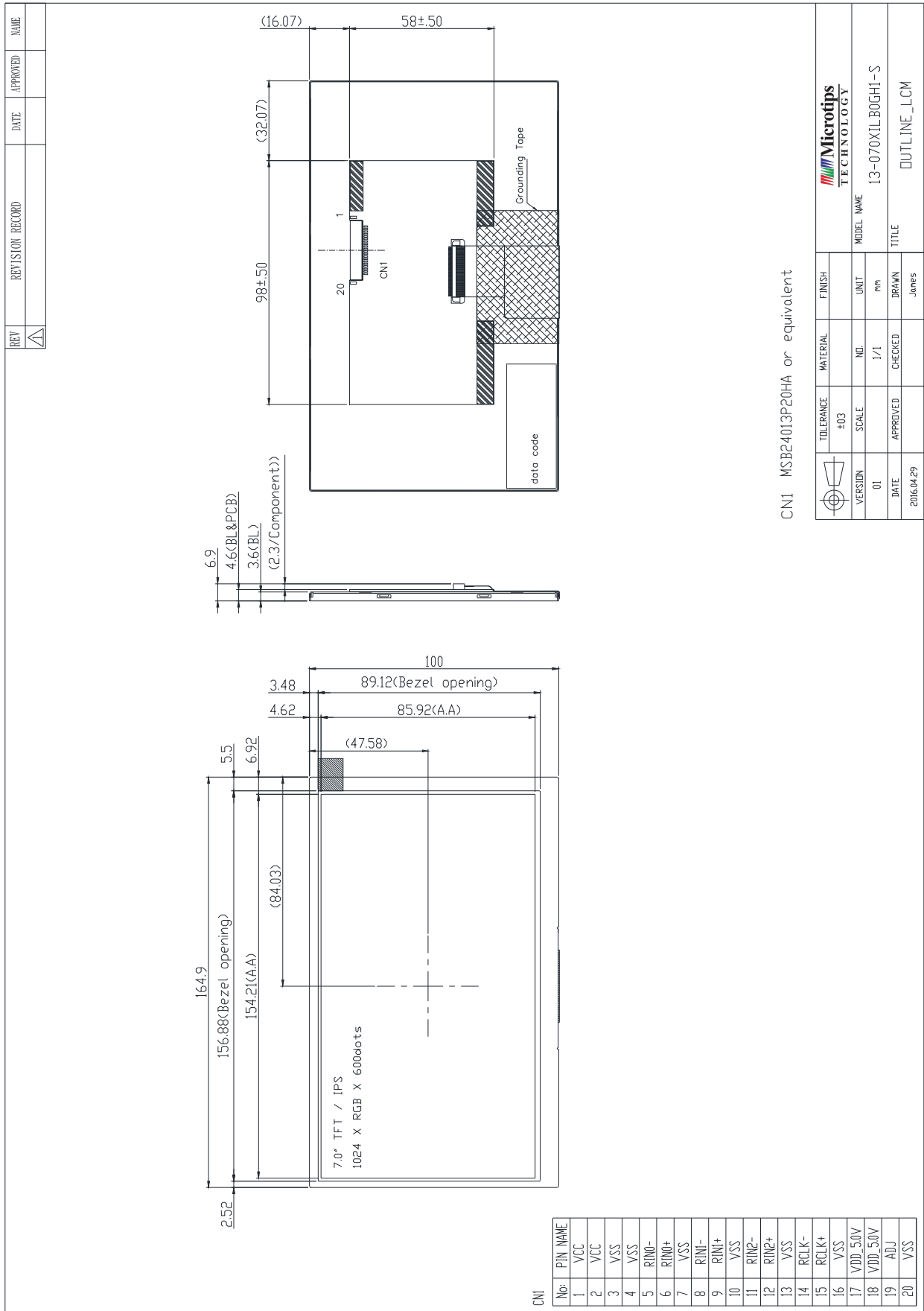

3. PIN DESCRIPTION (Connector Part No: MSB24013P20HA or equivalent)

Pin No.	Symbol	I/O	Function	Remark
1	VCC	P	Power Supply Logic voltage +3.3V	
2	VCC	P	Power Supply Logic voltage +3.3V	
3	VSS	P	Ground	
4	VSS	P	Ground	
5	RIN0-	I	Negative LVDS differential data input	
6	RIN0+	I	Positive LVDS differential data input	
7	VSS	P	Ground	
8	RIN1-	I	Negative LVDS differential data input	
9	RIN1+	I	Positive LVDS differential data input	
10	VSS	P	Ground	
11	RIN2-	I	Negative LVDS differential data input	
12	RIN2+	I	Positive LVDS differential data input	
13	VSS	P	Ground	
14	RCLK-	I	Negative LVDS differential clock input	
15	RCLK+	I	Positive LVDS differential clock input	
16	VSS	P	Ground	
17	VDD_5V	P	Power Supply LED voltage +5V	
18	VDD_5V	P	Power Supply LED voltage +5V	
19	ADJ	I	Back-light Dimming control	
20	VSS	P	Ground	

Notes:

- 1) ADJ is brightness control Pin. The larger of the pulse duty is, the higher of the brightness.
- 2) ADJ signal is 0-3.3V. Operation frequency range is 20KHz

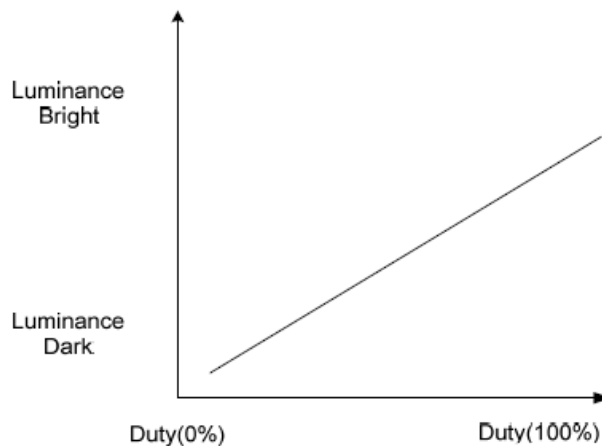

- 3) VSS PIN must be grounding, cannot be floating.

#### 4. ABSOLUTE MAXIMUM RATINGS

##### 4.1 Electrical Absolute Rating

##### 4.1.1 TFT LCD Module

Item	Symbol	Values		Unit	Note
		Min	Max.		
Power supply voltage	VCC	-0.3	4.0	V	
Power supply voltage	VDD_5V	0	6.0	V	

##### 4.1.2 Environment Absolute Rating

Item	Symbol	Values			Unit	Note
		Min	Typ	Max.		
Operating Temperature	Topa	-20		70	°C	Ambient temperature
Storage Temperature	Tstg	-30		80	°C	

5. BLOCK DIAGRAM

5.1 TFT LCD Module

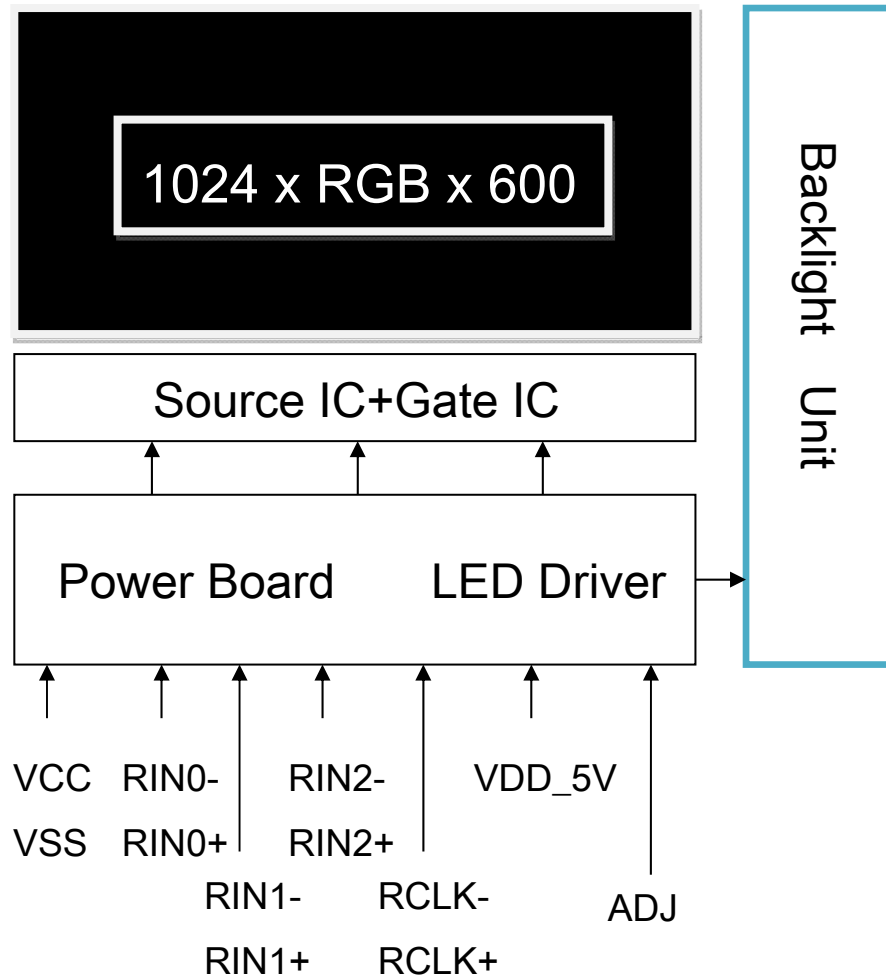

## 6. Relationship Between Displayed Color and Input

### 6.1 6 bit

	Display	MSB LSB						MSB LSB						MSB LSB						Gray scale level	
		R5	R4	R3	R2	R1	R0	G5	G4	G3	G2	G1	G0	B5	B4	B3	B2	B1	B0		
Basic color	Black	L	L	L	L	L	L	L	L	L	L	L	L	L	L	L	L	L	L	-	
	Blue	L	L	L	L	L	L	L	L	L	L	L	L	H	H	H	H	H	H	-	
	Green	L	L	L	L	L	L	H	H	H	H	H	H	L	L	L	L	L	L	-	
	Light Blue	L	L	L	L	L	L	H	H	H	H	H	H	H	H	H	H	H	H	-	
	Red	H	H	H	H	H	H	L	L	L	L	L	L	L	L	L	L	L	L	-	
	Purple	H	H	H	H	H	H	L	L	L	L	L	L	H	H	H	H	H	H	-	
	Yellow	H	H	H	H	H	H	H	H	H	H	H	H	L	L	L	L	L	L	-	
White	H	H	H	H	H	H	H	H	H	H	H	H	H	H	H	H	H	H	-		
Gray scale of Red	Black	L	L	L	L	L	L	L	L	L	L	L	L	L	L	L	L	L	L	L0	
	Dark ↑ ↓ Light	L	L	L	L	L	H	L	L	L	L	L	L	L	L	L	L	L	L	L1	
		L	L	L	L	H	L	L	L	L	L	L	L	L	L	L	L	L	L	L2	
			:						:						:						L3...L60
	Light	H	H	H	H	L	H	L	L	L	L	L	L	L	L	L	L	L	L	L61	
		H	H	H	H	H	L	L	L	L	L	L	L	L	L	L	L	L	L	L62	
Red	H	H	H	H	H	H	L	L	L	L	L	L	L	L	L	L	L	L	Red L63		
Gray scale of Green	Black	L	L	L	L	L	L	L	L	L	L	L	L	L	L	L	L	L	L	L0	
	Dark ↑ ↓ Light	L	L	L	L	L	L	L	L	L	L	L	H	L	L	L	L	L	L	L1	
		L	L	L	L	L	L	L	L	L	L	H	L	L	L	L	L	L	L	L2	
			:						:						:						L3...L60
	Light	L	L	L	L	L	L	H	H	H	H	L	H	L	L	L	L	L	L	L61	
		L	L	L	L	L	L	H	H	H	H	H	L	L	L	L	L	L	L	L62	
Green	L	L	L	L	L	L	H	H	H	H	H	H	L	L	L	L	L	L	Green L63		
Gray scale of Blue	Black	L	L	L	L	L	L	L	L	L	L	L	L	L	L	L	L	L	L	L0	
	Dark ↑ ↓ Light	L	L	L	L	L	L	L	L	L	L	L	L	L	L	L	L	H	L	L1	
		L	L	L	L	L	L	L	L	L	L	L	L	L	L	L	L	H	L	L2	
			:						:						:						L3...L60
	Light	L	L	L	L	L	L	L	L	L	L	L	L	H	H	H	H	L	H	L61	
		L	L	L	L	L	L	L	L	L	L	L	L	H	H	H	H	H	L	L62	
Blue	L	L	L	L	L	L	L	L	L	L	L	L	H	H	H	H	H	H	Blue L63		
Gray scale of White & Black	Black	L	L	L	L	L	L	L	L	L	L	L	L	L	L	L	L	L	L	L0	
	Dark ↑ ↓ Light	L	L	L	L	L	H	L	L	L	L	L	H	L	L	L	L	L	H	L1	
		L	L	L	L	H	L	L	L	L	L	H	L	L	L	L	L	H	L	L2	
			:						:						:						L3...L60
	Light	H	H	H	H	L	H	H	H	H	H	L	H	H	H	H	H	L	H	L61	
		H	H	H	H	H	L	H	H	H	H	H	L	H	H	H	H	H	L	L62	
White	H	H	H	H	H	H	H	H	H	H	H	H	H	H	H	H	H	H	White L63		

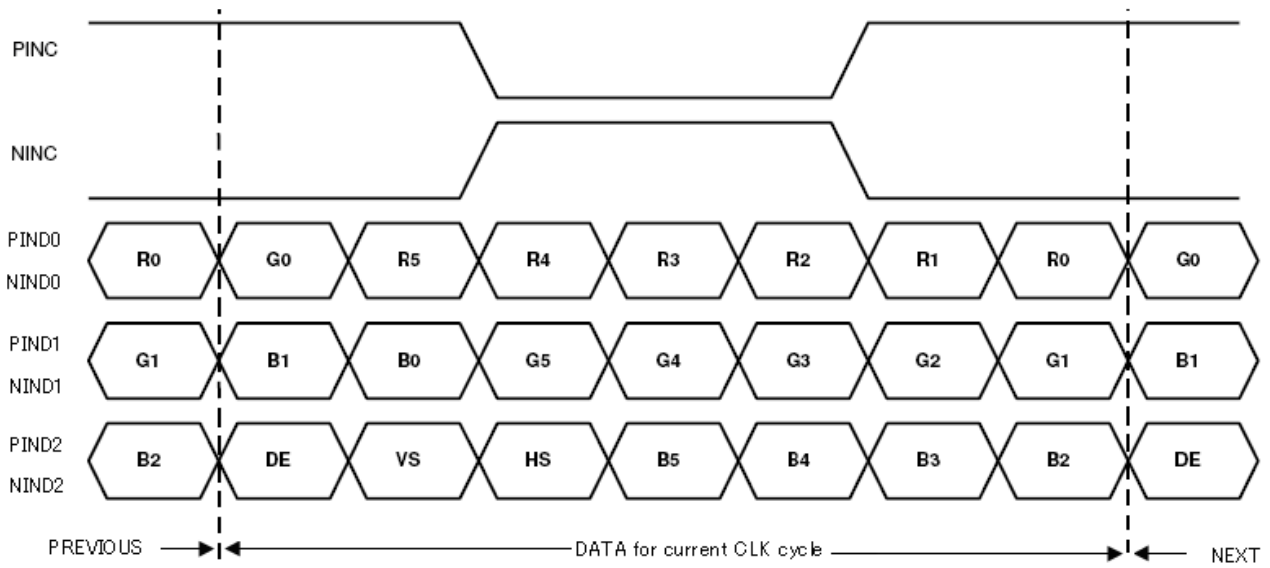

## 7. ELECTRICAL CHARACTERISTICS

### 7.1 TFT LCD Module

Item	Symbol	Values			Unit	Remark
		Min.	Typ.	Max.		
Supply Voltage	VCC	3.0	3.3	3.6	V	
	VDD_5V	4.5	5.0	5.5	V	
	VRF	-	-	100	mV p-p	Ripple voltage
Differential Input High Threshold	VTH	-	-	+100	mV	Vcm=+1.2V
Differential Input Low Threshold	VTL	-100	-	-	mV	Vcm=+1.2V
Magnitude differential Input Voltage	VID	100	-	600	mV	
Common Mode Voltage	Vcm	0.7	1.2	1.6	V	
Common Mode Voltage Offest	$\Delta$ Vcm	-	-	50	mV	Vcm=+1.2V
Supply Current	ICC	-	150	220	mA	VCC=3.3V
	IDD	-	500	600	mA	VDD_5V=5V
ADJ frequency		100	-	50K	Hz	
ADJ input voltage	VIH	3.0	-	3.3	V	
	VIL	0	-	0.3	V	
LED life time		-	50000	-	Hr	Note1

Note (1): The “LED life time” is defined as the module brightness decrease to 50% original brightness that the ambient temperature is 25°C 60% RH.

Note (2): VCC-dip condition

a.  $2.7\text{ V} \leq \text{VCC} < 3.0\text{V}$ ,  $t_d \leq 10\text{ ms}$

b.  $\text{VCC} > 3.0\text{V}$ , VCC-dip condition should be the same with VCC-turn-on condition °

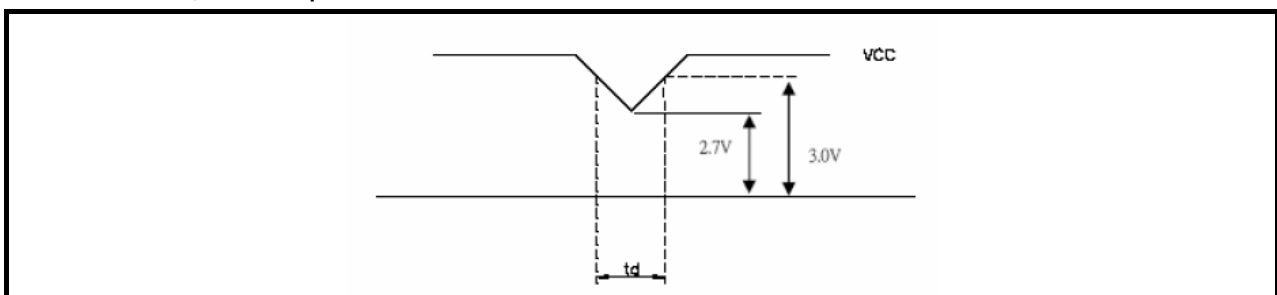

Note (3): The built-in LVDS receiver is compatible with (ANSI/TIA/TIA-644 ) standard.

Single-end Signals

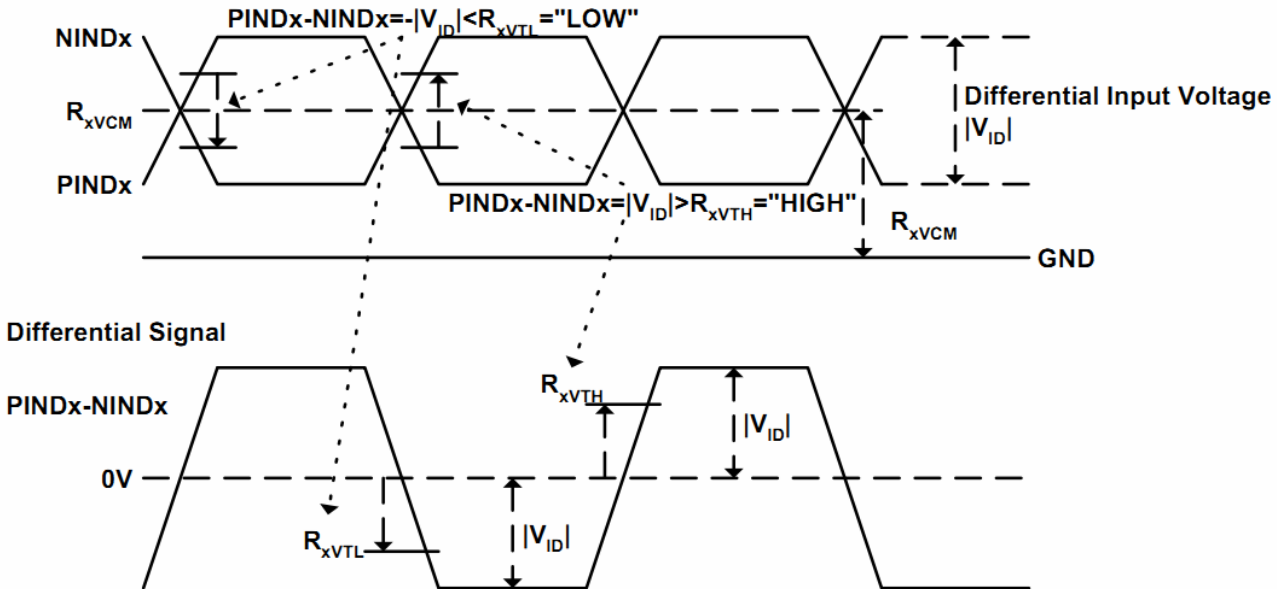

## 7.2 INTERFACE SPECIFICATIONS

### 7.2.1 DE mode Input signal characteristics

Signal	Parameter	Symbol	Min.	Typ.	Max.	Unit.	Note
DCLK	DCLK Frequency	fclk	40.8	51.2	67.2	MHz	
Horizontal	Horizontal display area	thd	-	1024	-	DCLK	
	HSD period time	th	1114	1344	1400	DCLK	
	HSD Blanking	thb+thfb	90	320	376	DCLK	
Vertical	Vertical display area	tvd	-	600	-	th	
	VSD period time	tv	610	635	800	th	
	VSD pulse width	tvb+tvfb	10	35	200	th	

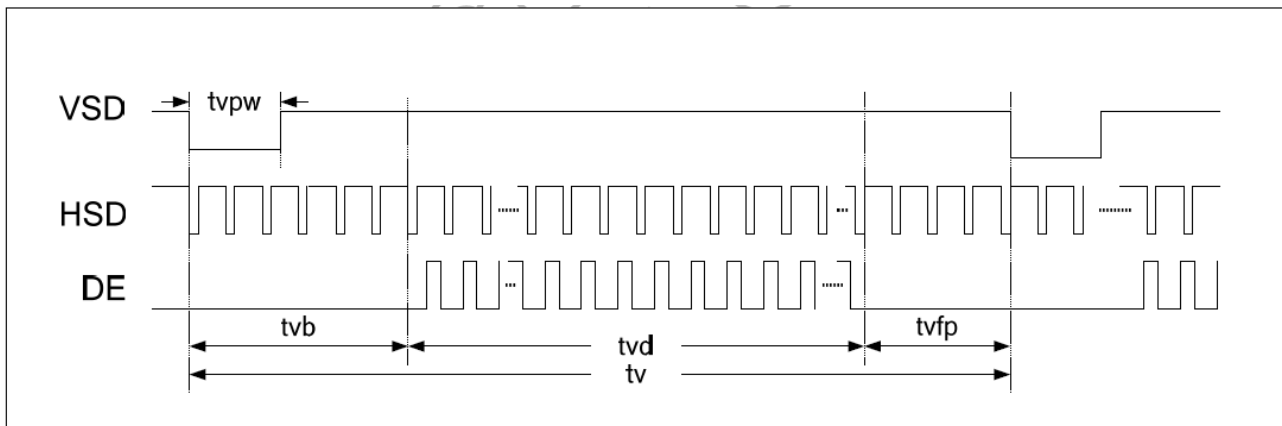
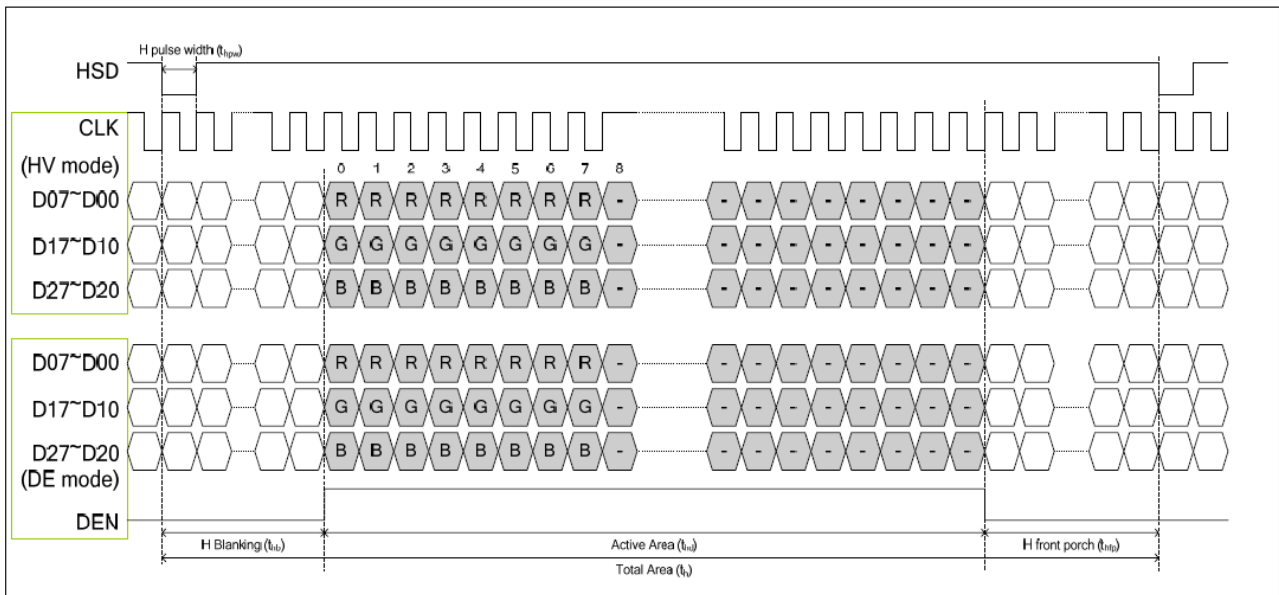

### 7.3 Power On / Off Sequence

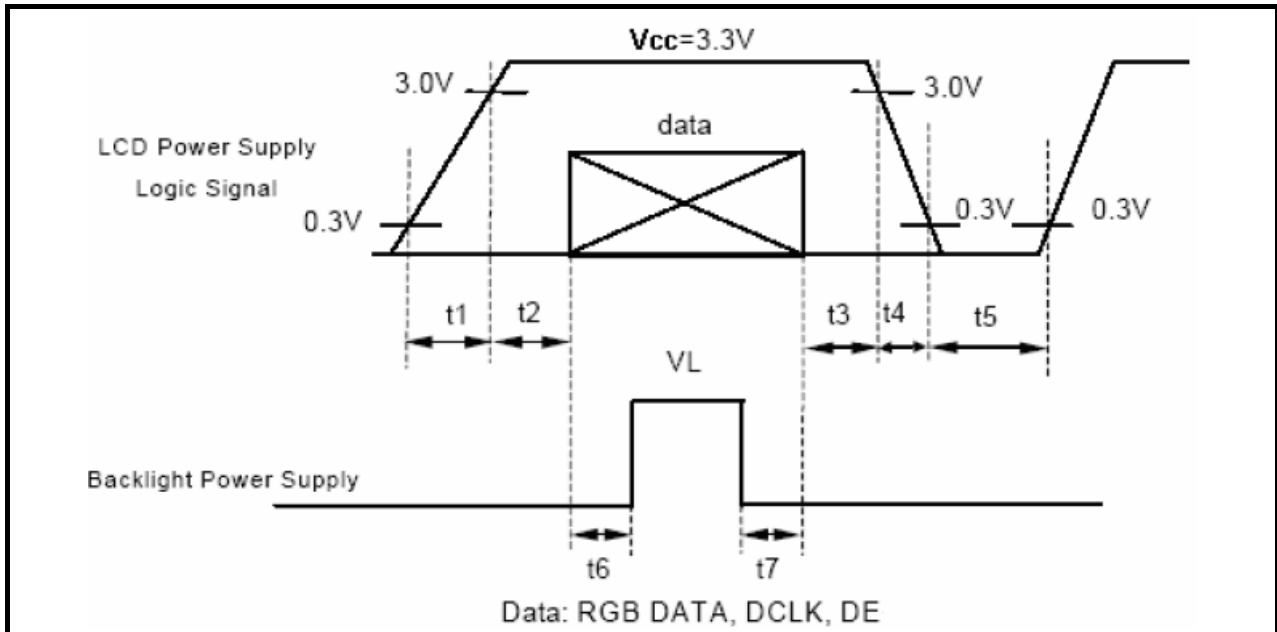

$t1 \leq 10\text{ms} : 1 \text{ sec} \leq t5$   
 $50\text{ms} \leq t2 : 200\text{ms} \leq t6$   
 $0 < t3 \leq 50\text{ms} : 200\text{ms} \leq t7$   
 $0 < t4 \leq 10\text{ms}$

### 8. OPTICAL CHARACTERISTICS

Item	Symbol	Condition	Min.	Typ.	Max.	Unit
Brightness	--	Note1, Note 3, ( $\theta = 0^\circ$ ; Normal Viewing Angle)	560	700	--	cd/m <sup>2</sup>
Uniformity	B-uni		70	75	-	%
Contrast Ratio	CR		640	800	--	--
Response Time	Tr		--	4	8	ms
	Tf	--	12	24	ms	
Color Chromaticity	White	Wx	0.260	0.310	0.360	--
		Wy	0.280	0.330	0.380	--
View angle	Horizontal	$\theta_{x+}$	80	85	--	
		$\theta_{x-}$	80	85	--	
	Vertical	$\theta_{Y+}$	80	85	--	
		$\theta_{Y-}$	80	85	--	

Note : The following optical specifications shall be measured in a darkroom or equivalent state(ambient luminance  $\leq 1$  lux, and at room temperature). The operation temperature is  $25^\circ\text{C} \pm 2^\circ\text{C}$ . The measurement method is shown in Note1.

Note1: The method of optical measurement:

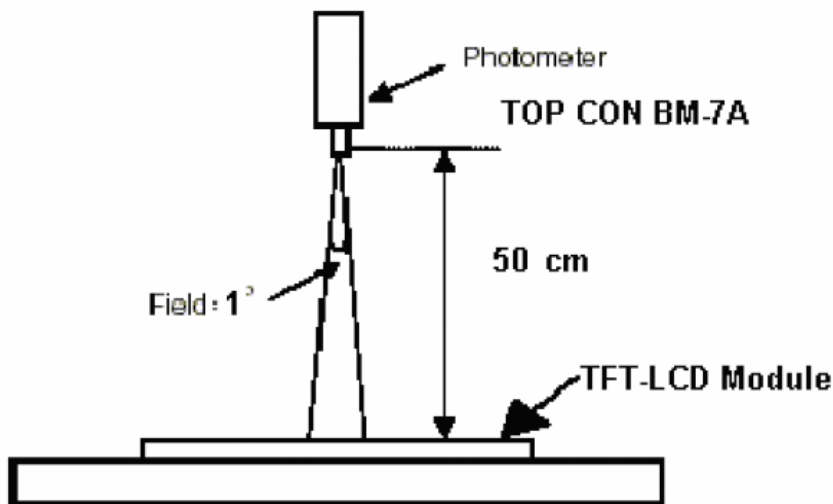

Note2: Measured at the center area of the panel and at the viewing angle of the  $\theta_x = \theta_y = 0^\circ$

Note3: Definition of Contrast Ratio (CR):

CR = Luminance with all pixels in white state  $\div$  Luminance with all pixels in Black state

Note 4: Definition of Viewing Angle:

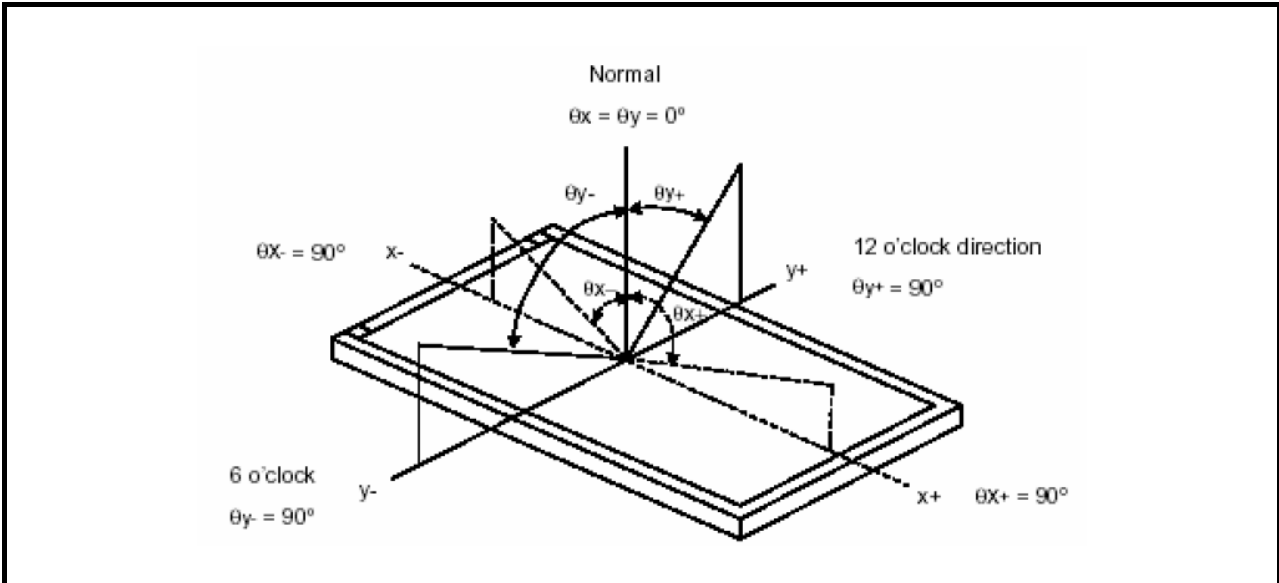

Note 5: Definition of Brightness Uniformity (B-uni):

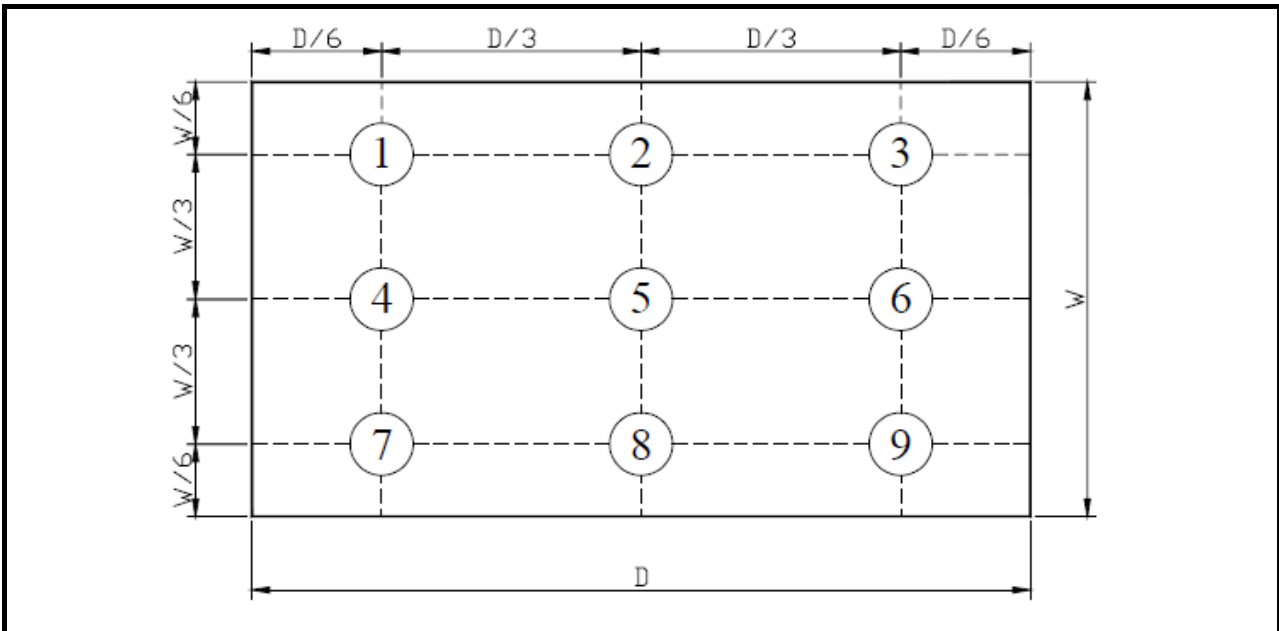

$$B\text{-uni} = (\text{Minimum luminance of 9 points} \div \text{Maximum luminance of 9 points}) \times 100\%$$

## Note 6: Definition of Response Time:

The Response Time is set initially by defining the “Rising Time ( $T_r$ )” and the “Falling Time ( $T_f$ )” respectively.  $T_r$  and  $T_f$  are defined as following figure

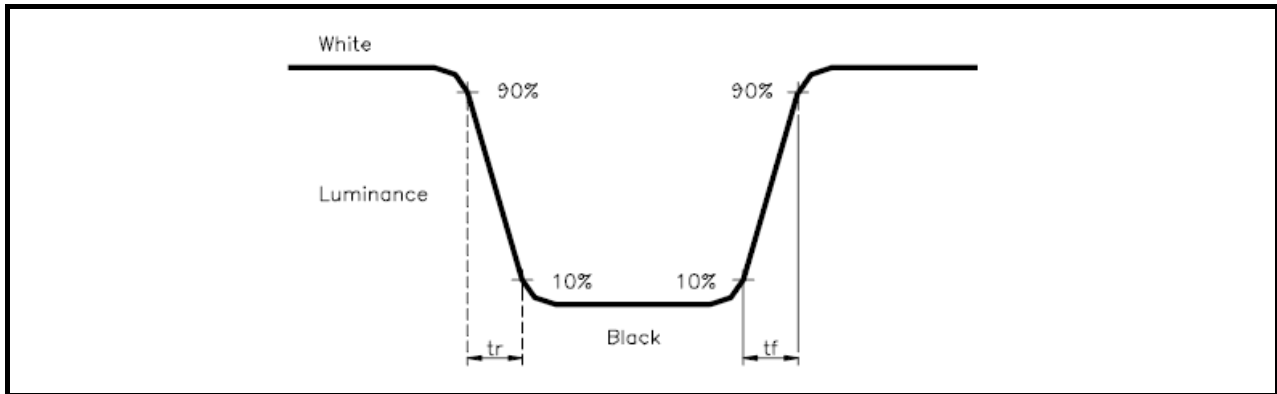

## Note 7: Definition of Chromaticity:

The color coordinates ( $W_x, W_y$ ), ( $R_x, R_y$ ), ( $G_x, G_y$ ), and ( $B_x, B_y$ ) are obtained with all pixels in the viewing field at white, red, green, and blue states, respectively.

9. RELIABILITY

9.1 Test Condition

9.1.1 Temperature and Humidity(Ambient Temperature)

Temperature : 25 ± 5°C

Humidity : 65 ± 5%

9.1.2 Operation

Unless specified otherwise, test will be conducted under function state.

9.1.3 Container

Unless specified otherwise, vibration test will be conducted to the product itself without putting it in a container.

9.1.4 Test Frequency

In case of related to deterioration such as shock test. It will be conducted only once.

9.2 TESTS

No.	ITEM	CONDITION CRITERION
1	High Temperature Storage	80°C, 120 hrs
2	Low Temperature Storage	-30°C, 120 hrs
3	High Temperature Operating	70°C, 120 hrs
4	Low Temperature Operating	-20°C, 120 hrs
5	High Temperature/Humidity Non-Operating	50°C, 90%RH, 120 hrs
6	Temperature Shock Non-Operating	-30°C ↔ 70°C (0.5hr each), 25 cycles
7	Vibration Test Non-Operating	Frequency:0 ~ 55 Hz Amplitude:1.5 mm Sweep Time:11min Test Period:6 Cycles for each Direction of X,Y,Z
9	Electro-static Discharge Non-Operating	150pF,330Ω Air:± 8KV;Contact: ±4KV 10 times/point;4 points/panel face

Note1: The test sample have recovery time for 24 hours at room temperature before the function check. In the standard conditions, there is no any touch panel function NG issue occurred.

### 9.3 JUDGMENT STANDARD

The judgment of the above test should be made as follow:

Pass: Normal display image with no obvious non-uniformity and no line defect. Partial transformation of the module parts should be ignored.

Fail: No display image, obvious non-uniformity, or line defects.

### 9.4 INCOMING INSPECTION STANDARDS

No.	Parameter	Criteria												
1	Operating	Display function: No Display malfunction (Major)												
		Contrast ratio (Black, White): Does not meet specified range in the spec. (Major) (Note:3)												
		Line Defect: No obvious Vertical and Horizontal line defect in bright, dark and colored. (Major) (Note:1)												
		Point Defect : Active area $\leq 5$ dots (Minor) (Note:1)												
		<table border="1"> <thead> <tr> <th rowspan="2">Item</th> <th>Acceptable number</th> <th rowspan="2">Total</th> </tr> <tr> <th>Active Area</th> </tr> </thead> <tbody> <tr> <td>Bright</td> <td>2</td> <td rowspan="2">5</td> </tr> <tr> <td>Dark</td> <td>4</td> </tr> </tbody> </table>	Item	Acceptable number	Total	Active Area	Bright	2	5	Dark	4			
Item	Acceptable number	Total												
	Active Area													
Bright	2	5												
Dark	4													
2	External Inspection (non-operating)	Non-uniformity: Visible through 5%ND filter. (Minor)												
		Foreign material in Black or White spots shape ( $W > 1/4L$ )												
		<table border="1"> <thead> <tr> <th>Zone Dimension</th> <th>Acceptable number</th> <th rowspan="3">Class Of Defects</th> <th rowspan="3">AQL Level</th> </tr> </thead> <tbody> <tr> <td><math>D &gt; 0.5</math></td> <td>0</td> </tr> <tr> <td><math>0.3 &lt; D \leq 0.5</math></td> <td>5</td> </tr> <tr> <td><math>D \leq 0.3</math></td> <td>*</td> <td>Minor</td> <td>1.5</td> </tr> </tbody> </table> <p><math>D = (\text{Long} + \text{Short}) / 2</math> * : Disregard</p>	Zone Dimension	Acceptable number	Class Of Defects	AQL Level	$D > 0.5$	0	$0.3 < D \leq 0.5$	5	$D \leq 0.3$	*	Minor	1.5
		Zone Dimension	Acceptable number	Class Of Defects			AQL Level							
		$D > 0.5$	0											
$0.3 < D \leq 0.5$	5													
$D \leq 0.3$	*	Minor	1.5											
Foreign Material in Line or spiral shape ( $W \leq 1/4L$ ) (Note: 4)														
<table border="1"> <thead> <tr> <th>Zone L (mm) \ W(mm)</th> <th>Acceptable number</th> <th rowspan="3">Class Of Defects</th> <th rowspan="3">AQL Level</th> </tr> </thead> <tbody> <tr> <td><math>L &gt; 5</math>    <math>W &gt; 0.1</math></td> <td>0</td> </tr> <tr> <td><math>0.5 &lt; L \leq 5</math>    <math>0.03 &lt; W \leq 0.1</math></td> <td>5</td> </tr> <tr> <td><math>L \leq 0.5</math>    <math>W \leq 0.03</math></td> <td>*</td> <td>Minor</td> <td>1.5</td> </tr> </tbody> </table> <p>L : Length    W : Width    * : Disregard</p>	Zone L (mm) \ W(mm)	Acceptable number	Class Of Defects	AQL Level	$L > 5$ $W > 0.1$	0	$0.5 < L \leq 5$ $0.03 < W \leq 0.1$	5	$L \leq 0.5$ $W \leq 0.03$	*	Minor	1.5		
Zone L (mm) \ W(mm)	Acceptable number	Class Of Defects			AQL Level									
$L > 5$ $W > 0.1$	0													
$0.5 < L \leq 5$ $0.03 < W \leq 0.1$	5													
$L \leq 0.5$ $W \leq 0.03$	*	Minor	1.5											
2	External Inspection (non-operating)	Dimension: Outline (Major)												
		Bezel appearance: uneven (Minor)												
		Scratch on the polarize: (Note:2)												
		<table border="1"> <thead> <tr> <th>Zone L (mm) \ W(mm)</th> <th>Acceptable number</th> <th rowspan="2">Class Of Defects</th> <th rowspan="2">AQL Level</th> </tr> </thead> <tbody> <tr> <td>--    <math>W &gt; 0.1</math></td> <td>0</td> </tr> <tr> <td><math>L \leq 3</math>    <math>W \leq 0.1</math></td> <td>3</td> <td>Minor</td> <td>1.5</td> </tr> </tbody> </table> <p>L : Length    W : Width    * : Disregard</p>	Zone L (mm) \ W(mm)	Acceptable number	Class Of Defects	AQL Level	-- $W > 0.1$	0	$L \leq 3$ $W \leq 0.1$	3	Minor	1.5		
		Zone L (mm) \ W(mm)	Acceptable number	Class Of Defects			AQL Level							
-- $W > 0.1$	0													
$L \leq 3$ $W \leq 0.1$	3	Minor	1.5											
Dent or bubble on the polarize (Note:2)														
<table border="1"> <thead> <tr> <th>Zone Dimension</th> <th>Acceptable number</th> <th rowspan="2">Class Of Defects</th> <th rowspan="2">AQL Level</th> </tr> </thead> <tbody> <tr> <td><math>D \leq 0.3</math></td> <td>*</td> </tr> <tr> <td><math>D \leq 0.5</math></td> <td>3</td> <td>Minor</td> <td>1.5</td> </tr> </tbody> </table> <p><math>D = (\text{Long} + \text{Short}) / 2</math> * : Disregard</p>	Zone Dimension	Acceptable number	Class Of Defects	AQL Level	$D \leq 0.3$	*	$D \leq 0.5$	3	Minor	1.5				
Zone Dimension	Acceptable number	Class Of Defects			AQL Level									
$D \leq 0.3$	*													
$D \leq 0.5$	3	Minor	1.5											

Class of defects			Definition
	<b>Major</b>	AQL 0.65%	
<b>Minor</b>	AQL 1.5%		It is a defect that will not result in functioning problem with deviation classified.

**Note1:**

- (a) Bright point defect is defined as point defect of R,G,B with area >1/2 pixel respectively
- (b) Dark point defect is defined as visible in full white pattern.
- (c) Definition of distribution of point defect is as follows:
  - minimum separation between dark point defects should be larger than 5mm.
  - minimum separation between bright point defects should be larger than 5mm.
- (d) Definition of joined bright point defect and joined dark point defect are as follows:
  - Two or more joined bright point defects must be nil.
  - Three joined dark point defects must be nil.
  - Coupling of one dark and one bright point in junction is counted as one dark and bright spot with 1 pair maximum.
  - Two Joined dark point is counted as two dark points with 2 pair maximum.

**Note2:** The external inspection should be conducted at the distance  $30 \pm 5$ cm between the eyes of inspector and the panel.

**Note3:** Luminance measurement for contrast ratio is at the distance  $50 \pm 5$ cm between the detective head and the panel with ambient luminance less than 1 lux. Contrast ratio is obtained at optimum view angle.

**Note4:** W-Width in mm , L-length of Max.(L1,L2) in mm.

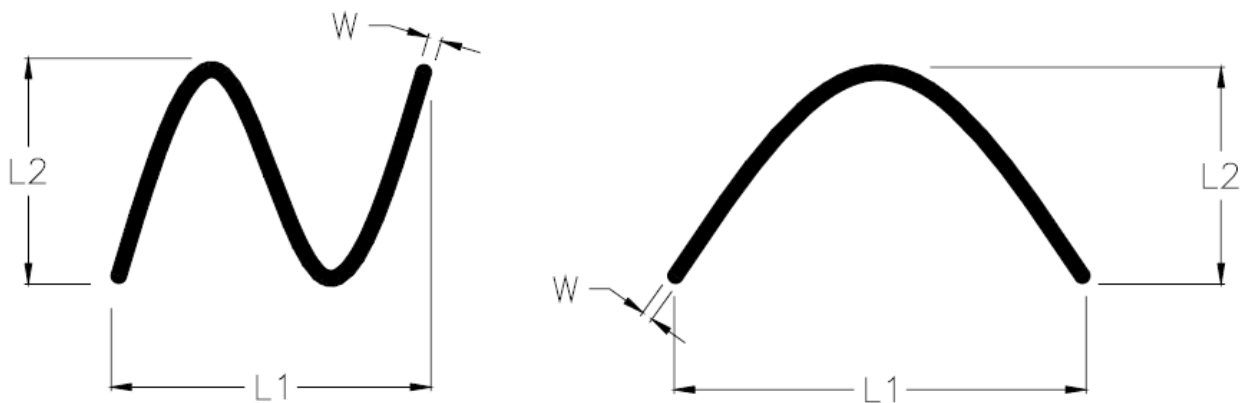

## 9.5 Sampling Condition

Unless otherwise agree in written, the sampling inspection shall be applied to the incoming inspection of customer.

Lot size: Quantity of shipment lot per model.

Sampling type: normal inspection, single sampling

Sampling table: MIL-STD-105E

Inspection level: Level II

## 9.6 Inspection conditions

The LCD shall be inspected under 40W white fluorescent light.

$\theta \leq 45^\circ$  inspection under non-operating condition.

$\theta \leq 5^\circ$  inspection under operating condition

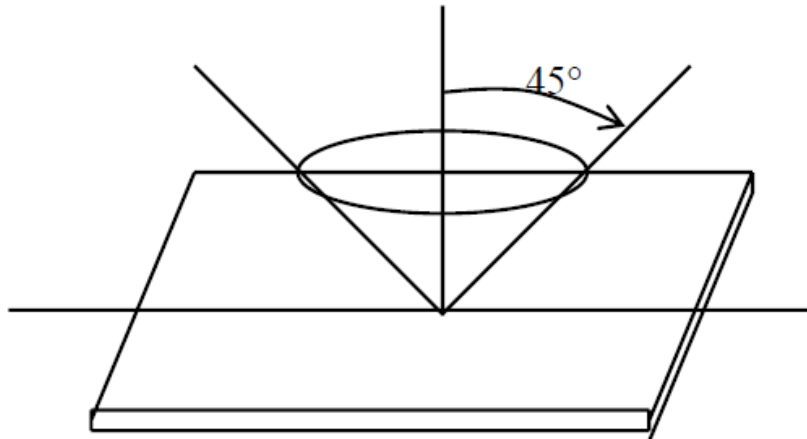

## 10. PRECAUTION RELATING PRODUCT HANDLING

### 10.1 SAFETY

- 10.1.1 If the LCD panel breaks , be careful not to get the liquid crystal to touch your skin.
- 10.1.2 If the liquid crystal touches your skin or clothes , please wash it off immediately by using soap and water.

### 10.2 HANDLING

- 10.2.1 Avoid any strong mechanical shock which can break the glass.
- 10.2.2 Avoid static electricity which can damage the CMOS LSI—When working with the module, be sure to ground your body and any electrical equipment you may be using.
- 10.2.3 Do not remove the panel or frame from the module.
- 10.2.4 The polarizing plate of the display is very fragile. So , please handle it very carefully, Do not touch, push or rub the exposed polarizing with anything harder than an HB pencil lead (glass , tweezers , etc.)
- 10.2.5 Do not wipe the polarizing plate with a dry cloth, as it may easily scratch the surface of plate.
- 10.2.6 Do not touch the display area with bare hands , this will stain the display area.
- 10.2.7 Do not use ketonics solvent & aromatic solvent. Use with a soft cloth soaked with a cleaning naphtha solvent.
- 10.2.8 To control temperature and time of soldering is  $280 \pm 10^{\circ}\text{C}$  and 3-5 sec.
- 10.2.9 To avoid liquid (include organic solvent) stained on LCM.

### 10.3 STORAGE

- 10.3.1 Store the panel or module in a dark place where the temperature is  $25^{\circ}\text{C} \pm 5^{\circ}\text{C}$  and the humidity is below 65% RH.
- 10.3.2 Do not place the module near organics solvents or corrosive gases.
- 10.3.3 Do not crush, shake, or jolt the module.