

Doc. Number :

- Tentative Specification
- Preliminary Specification
- Approval Specification

MODEL NO.: G156HCE
SUFFIX: E01

Customer:	
APPROVED BY	SIGNATURE
<u>Name / Title</u>	_____
Note	

Please return 1 copy for your confirmation with your signature and comments.	

Approved By	Checked By	Prepared By
陳立錚	林秋森	阮志昌

CONTENTS

1. GENERAL DESCRIPTION	6
1.1 OVERVIEW	6
1.2 GENERAL SPECIFICATIONS	6
2. MECHANICAL SPECIFICATIONS	6
2.1 CONNECTOR TYPE	6
3. ABSOLUTE MAXIMUM RATINGS	7
3.1 ABSOLUTE RATINGS OF ENVIRONMENT	7
3.2 ELECTRICAL ABSOLUTE RATINGS	7
3.2.1 TFT LCD MODULE	7
3.2.2 BACKLIGHT CONVERTER.....	8
4. ELECTRICAL SPECIFICATIONS	8
4.1 FUNCTION BLOCK DIAGRAM	8
4.2. INTERFACE CONNECTIONS	8
4.3 ELECTRICAL CHARACTERISTICS	10
4.3.1 LCD ELETRONICS SPECIFICATION	10
4.3.2 LED CONVERTER SPECIFICATION.....	13
4.3.3 BACKLIGHT UNIT.....	14
4.4 DISPLAY PORT INPUT SIGNAL TIMING SPECIFICATIONS.....	14
4.4.1 ELECTRICAL SPECIFICATIONS.....	14
4.4.2 COLOR DATA INPUT ASSIGNMENT.....	16
4.5 DISPLAY TIMING SPECIFICATIONS	17
4.6 POWER ON/OFF SEQUENCE.....	18
5. OPTICAL CHARACTERISTICS	21
5.1 TEST CONDITIONS	21
5.2 OPTICAL SPECIFICATIONS	21
6. RELIABILITY TEST ITEM	25
7. PACKING	26
7.1 PACKING SPECIFICATIONS	26
7.2 PACKING METHOD	26
7.3 PALLET.....	27
7.4 UN-PACK METHOD	27
8. MODULE LABEL.....	28
8.1 INX MODULE LABEL	28
9. PRECAUTIONS	29
9.1 ASSEMBLY AND HANDLING PRECAUTIONS	29

9.2 STORAGE PRECAUTIONS	29
9.3 OPERATION PRECAUTIONS	29
9.4 SAFETY PRECAUTIONS	29
9.5 SAFETY STANDARDS	30
9.6 OTHER	30
Appendix. OUTLINE DRAWING	31

REVISION HISTORY

Version	Date	Page	Description
2.0	2019.05.17	ALL	Spec Ver.2.0 was first issued.
2.1	2020.04.24	20	Color Chromaticity White (Wx/ Wy) : from (0.313/0.329)±0.05 to (0.305/0.340) ±0.03 .
	2020.04.24	30	Modify 2D drawing
2.2	2020.08.20	21	Contrast Ratio min from 500:1 to 700:1.
		25	High Temperature & High Humidity Operation Test from 60°C, 90%RH to 50°C, 80%RH.
2.3	2021.03.5	6	Power Consumption: Total from 10.38 W to 11.1W (Max.)

1. GENERAL DESCRIPTION

1.1 OVERVIEW

G156HCE-E01 is a 15.6" (15.6" diagonal) TFT Liquid Crystal Display IAV module with LED Backlight unit and 40 pins eDP interface. This module supports 1920 x 1080 FHD AAS mode and can display 16.7M colors

1.2 GENERAL SPECIFICATIONS

Item	Specification	Unit	Note
Screen Size	15.6 diagonal		
Driver Element	a-si TFT active matrix	-	-
Pixel Number	1920 x R.G.B. x 1080	pixel	-
Pixel Pitch	0.17925 (H) x 0.17925 (V)	mm	-
Pixel Arrangement	RGB vertical stripe	-	-
Display Colors	16.7M	color	-
Transmissive Mode	Normally Black	-	-
Surface Treatment	Hard coating (3H), Anti-Glare	-	-
Luminance, White	450	Cd/m2	
Color Gamut	72%	NTSC	
Power Consumption	Total 11.1 W (Max.) @ cell 1.5W (Max.), (BL 9.6 W (Max.))		(1)

Note (1) The specified power consumption (with converter efficiency) is under the conditions at VCCS = 3.3 V, fv = 60 Hz, LED_VCCS = Typ, fPWM = 200 Hz, Duty=100% and Ta = 25 ± 2 °C, whereas mosaic pattern is displayed.

2. MECHANICAL SPECIFICATIONS

Item		Min.	Typ.	Max.	Unit	Note
Module Size	Horizontal (H)	351.54	351.84	352.14	mm	(1)(2)
	Vertical (V)	208.58	208.88	209.18	mm	
	Thickness (T)	-	-	6.5	mm	
Active Area	Horizontal	-	344.16	-	mm	
	Vertical	-	193.59	-	mm	
Weight		-	550		g	

Note (1) Please refer to the attached drawings for more information of front and back outline dimensions.

Note (2) Dimensions are measured by caliper.



2.1 CONNECTOR TYPE

Please refer appendix outline drawing for detail design.

Connector 1 Part No.: IPEX 20455-040E-76 User's connector Part No: IPEX 20453-040T-03

Connector 2 Part No.: ACES 50620-00501-001

3. ABSOLUTE MAXIMUM RATINGS

3.1 ABSOLUTE RATINGS OF ENVIRONMENT

Item	Symbol	Value		Unit	Note
		Min.	Max.		
Storage Temperature	TST	-20	+70	°C	(1)(2)
Operating Ambient Temperature	TOP	0	+60	°C	(1)(2)

Note (1) Temperature and relative humidity range is shown in the figure below.

(a) 90 %RH Max. ($T_a \leq 40$ °C).

(b) Wet-bulb temperature should be 39 °C Max. ($T_a > 40$ °C).

(c) No condensation.

Note(2) The absolute maximum rating values of this product are not allowed to be exceeded at any times. The module should not be used over the absolute maximum rating value. It will cause permanently unrecoverable function fail in such an condition

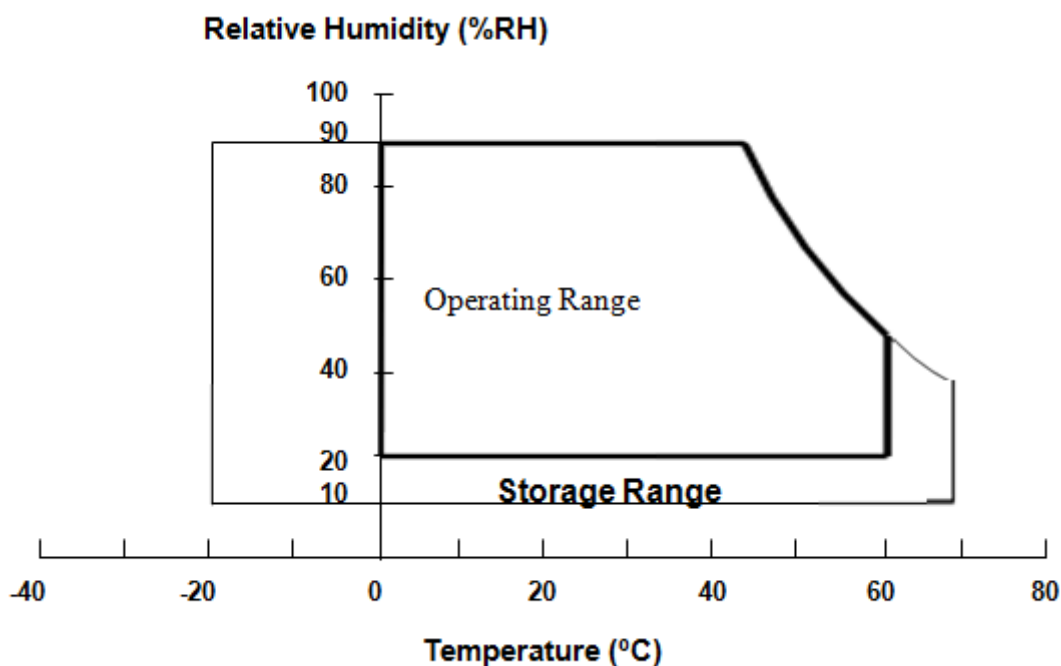

3.2 ELECTRICAL ABSOLUTE RATINGS

3.2.1 TFT LCD MODULE

Item	Symbol	Value		Unit	Note
		Min.	Max.		
Power Supply Voltage	V _{CC}	-0.3	4.0	V	(1)
Logic Input Voltage	V _{IN}	-0.3	4.0	V	

3.2.2 BACKLIGHT CONVERTER

Item	Symbol	Value			Unit	Note
		Min.	Typ	Max.		
Converter Voltage	LED_V _{in}	0	12.0	18.0	V	(1), (2) Duty=100%
Enable Voltage	LED_EN	0	3.3	5.5	V	
Backlight Adjust	LED_PWM	0	3.3	5.5	V	(1), (2) Pulse Width ≤ 10msec. and Duty ≤ 10%

Note (1) Permanent damage to the device may occur if maximum values are exceeded. Function operation should be restricted to the conditions described under Normal Operating Conditions.

Note (2) Specified values are for input pin of LED light bar at Ta=25±2 °C (Refer to 4.3.3 and 4.3.4 for further information)

4. ELECTRICAL SPECIFICATIONS

4.1 FUNCTION BLOCK DIAGRAM

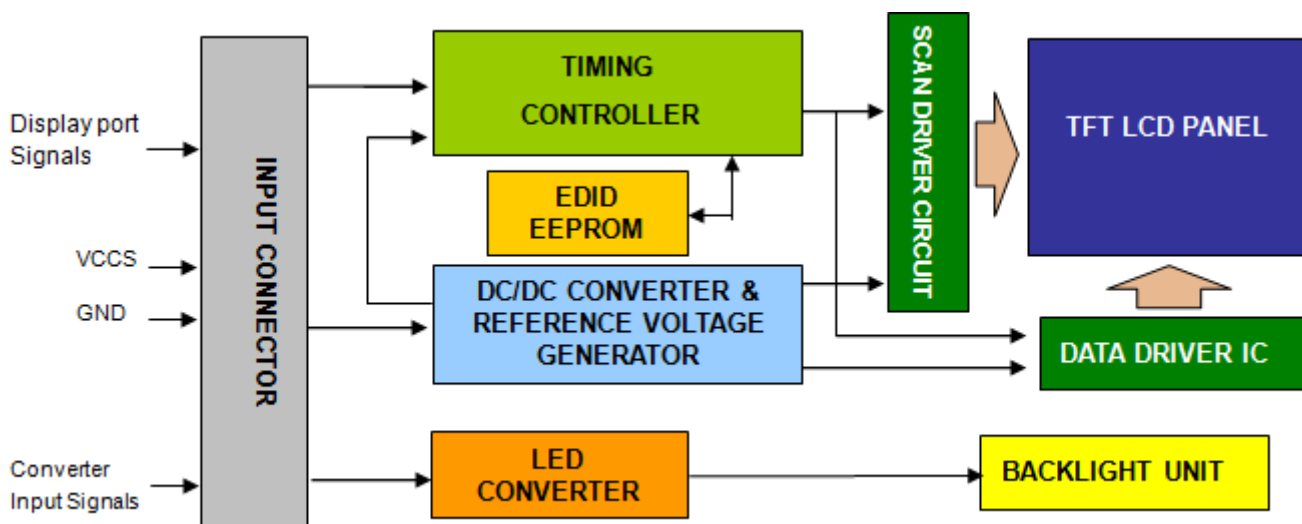

4.2. INTERFACE CONNECTIONS

PIN ASSIGNMENT

Pin	Symbol	Description	Remark
1	NC	No Connection (Reserved for LCD test)	
2	NC	No Connection (Reserved for LCD test)	
3	NC	No Connection (Reserved for LCD test)	
4	NC	No Connection (Reserved for LCD test)	
5	NC	No Connection (Reserved for LCD test)	
6	VDD	USB power	
7	VDD	USB power	
8	VSS	USB GND	

9	D+	USB D+	
10	D-	USB D-	
11	NC	No Connection (Reserved for LCD test)	
12	LED_VCCS	BL Power	
13	LED_VCCS	BL Power	
14	LED_VCCS	BL Power	
15	LED_VCCS	BL Power	
16	NC	No Connection (Reserved for LCD test)	
17	NC	No Connection (Reserved for LCD test)	
18	LED_PWM	PWM Dimming Control Signal of LED Converter	
19	LED_EN	BL_Enable Signal of LED Converter	
20	BL_GND	BL Ground	
21	BL_GND	BL Ground	
22	BL_GND	BL Ground	
23	BL_GND	BL Ground	
24	HPD	Hot Plug Detect	
25	GND	Ground	
26	GND	Ground	
27	NC	No Connection (Reserved for LCD test)	
28	VCCS	Power Supply +3.3 V (typical)	
29	VCCS	Power Supply +3.3 V (typical)	
30	GND	Ground	
31	AUX-	Complement Signal-Auxiliary Channel	
32	AUX+	True Signal-Auxiliary Channel	
33	GND	Ground	
34	ML0+	True Signal-Main Lane 0	
35	ML0-	Complement Signal-Lane 0	
36	GND	Ground	
37	ML1+	True Signal-Main Lane 1	
38	ML1-	Complement Signal-Lane 1	
39	GND	Ground	
40	NC	No Connection (Reserved for LCD test)	

Note (1)The first pixel is odd as shown in the following figure.

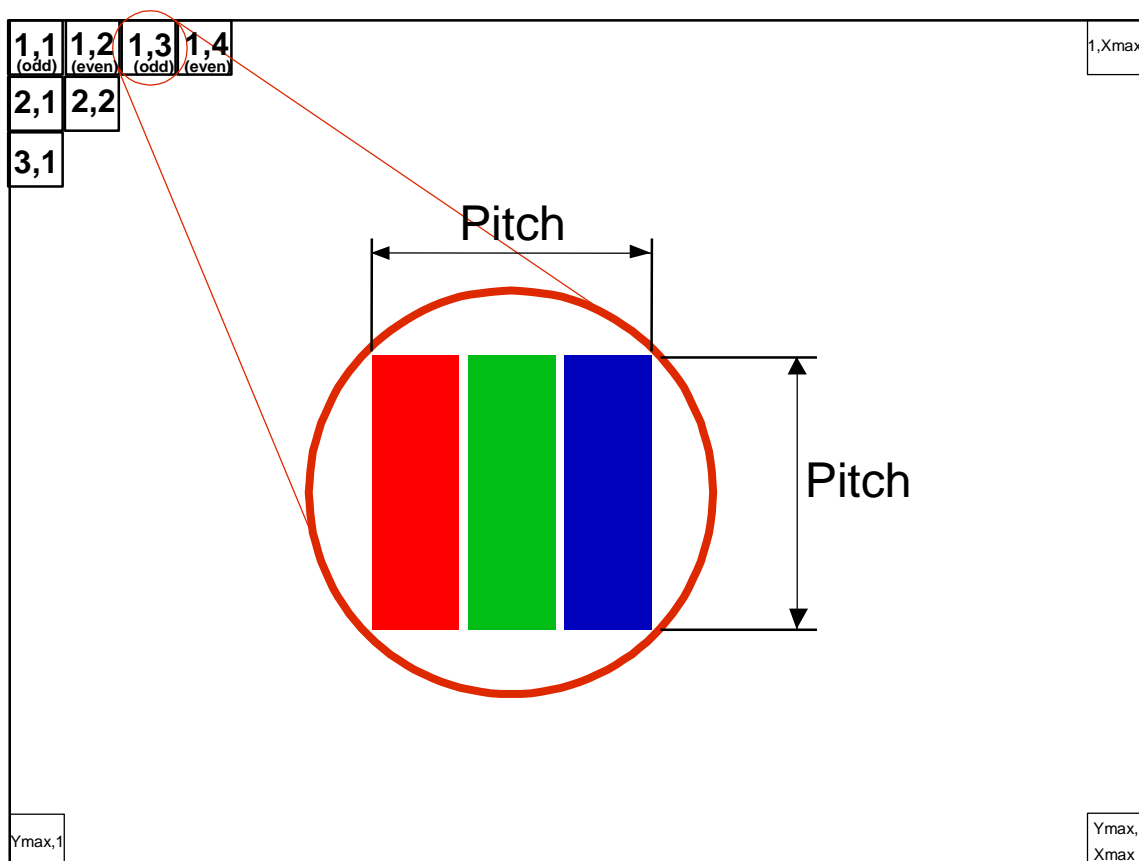

4.3 ELECTRICAL CHARACTERISTICS

4.3.1 LCD ELETRONICS SPECIFICATION

Parameter	Symbol	Value			Unit	Note
		Min.	Typ.	Max.		
Power Supply Voltage	VCCS	3.0	3.3	3.6	V	(1)
Ripple Voltage	V _{RP}	-	50	-	mV	(1)
Inrush Current	I _{RUSH}	-	-	1.5	A	(1),(2)
Peak Current	I _{Peak}			1.5	A	(1),(2)
Power Supply Current	Mosaic		198	237	mA	(3)a
	Black		176	211	mA	(3)
HPD	High Level	2.25	-	2.75	V	(5)
	Low Level	0	-	0.4	V	(5)
HPD Impedance	R _{HPD}	30K			ohm	(4)

Note (1) The ambient temperature is $T_a = 25 \pm 2$ °C.

Note (2) I_{RUSH}: the maximum current when VCCS is rising

I_{Peak}: the maximum current of the first 100ms after power-on

Measurement Conditions: Shown as the following figure. Test pattern: black.

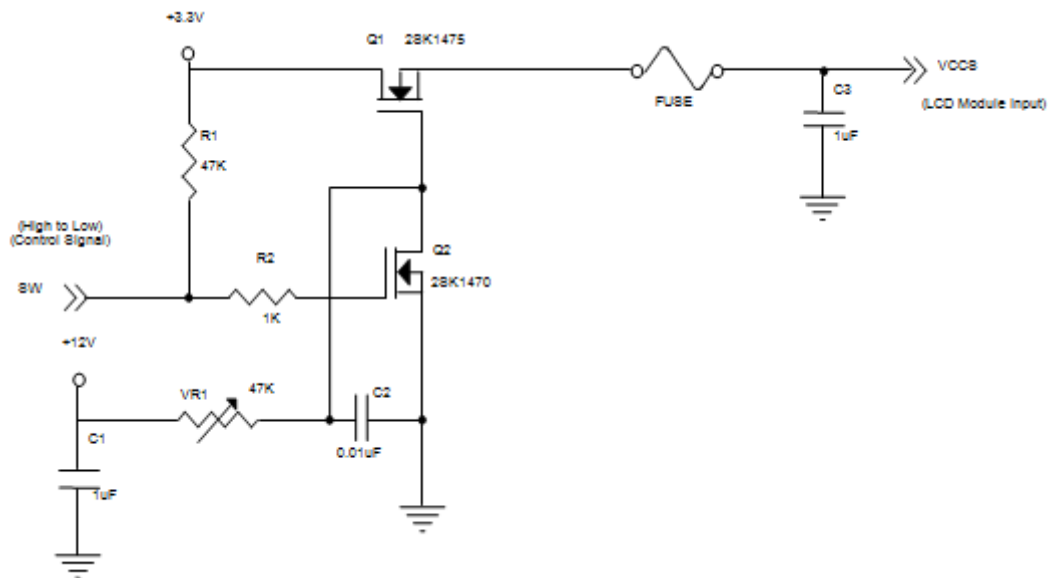

VCCS rising time is 0.5ms

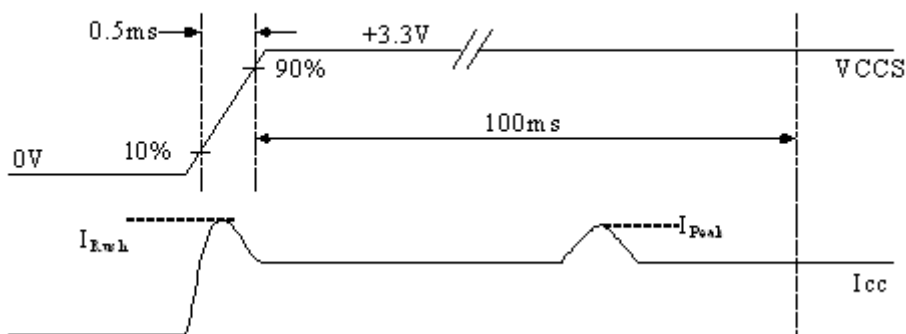

Note (3) The specified power supply current is under the conditions at VCCS = 3.3 V, $T_a = 25 \pm 2 \text{ }^\circ\text{C}$, DC Current and $f_v = 60 \text{ Hz}$, whereas a power dissipation check pattern below is displayed.

a. Mosaic Pattern

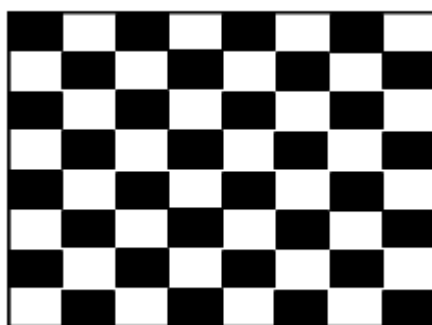

Active Area

Note (4) The specified signals have equivalent impedances pull down to ground in the LCD module respectively. Customers should keep the input signal level requirement with the load of LCD module. Please refer to Note (4) of 4.3.2 LED CONVERTER SPECIFICATION to obtain more information.

Note (5) When a source detects a low-going HPD pulse, it must be regarded as a HPD event. Thus, the source must read the link / sink status field or receiver capability field of the DPCD and take corrective action.

4.3.2 LED CONVERTER SPECIFICATION

Parameter	Symbol	Value			Unit	Note	
		Min.	Typ.	Max.			
Converter Power Supply Voltage	LED_Vin	10.8	12.0	13.2	V		
Converter Power Supply Current	li	0.6	0.8	1.0	A	@LED_Vin= 12V Duty=100%	
Converter Input Rush Current	lirsh			2	A	@LED_Vin rising = 1mS	
Power Consumption	P _{LED}			9.6	W	@ LED_Vin = 12V Duty=100%	
EN Control Level	Backlight on	LED_EN	2.0	3.3	5.5	V	
	Backlight off		0	0	0.15		
PWM Control Level	PWM High Level	LED_PWM	2.0	3.3	5.5	V	
	PWM Low Level		0	0	0.15		
PWM Control Duty Ratio			10	--	100	%	
PWM Control Frequency		f _{PWM}	190	200	20k	Hz	
LED Life Time		L _L	50,000			Hrs	(2)

Note (1) LED light bar input voltage and current are measured by utilizing a true RMS multimeter as shown below:

Note (2) The lifetime of LED is estimated data and defined as the time when it continues to operate under the conditions at Ta = 25±2°C and Duty 100% until the brightness becomes ≤ 50% of its original value. Operating LED under high temperature environment will reduce life time and lead to color shift..

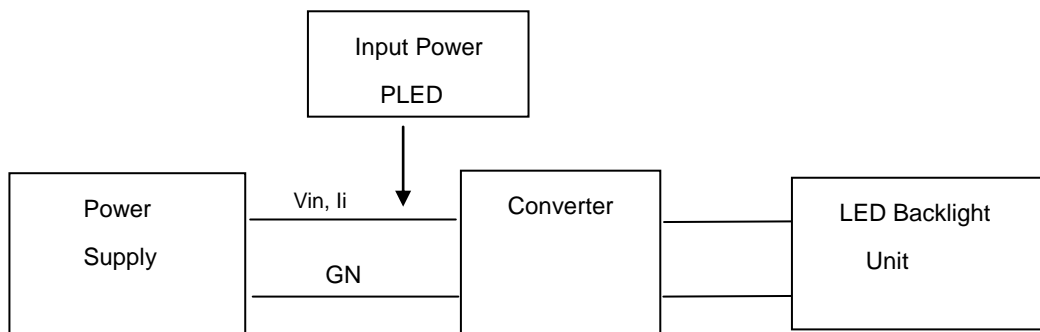

4.3.3 BACKLIGHT UNIT

Ta = 25 ± 2 °C

Parameter	Symbol	Value			Unit	Note
		Min.	Typ.	Max.		
LED Light Bar Power Supply Voltage	VL	23.8	28.4	30.6	V	(1)(2)(Duty100%)
LED Light Bar Power Supply Current	IL	--	47	--	mA	
Power Consumption	PL			8.63	W	(3)
LED Life Time	LBL	50000	-	-	Hrs	(4)

Note (1) LED current is measured by utilizing a high frequency current meter as shown below :

Note (2) For better LED light bar driving quality, it is recommended to utilize the adaptive boost converter with current balancing function to drive LED light-bar.

Note (3) $P_L = I_L \times V_L$ (Without LED converter transfer efficiency)

Note (4) The lifetime of LED is defined as the time when it continues to operate under the conditions at Ta = 25 ± 2 °C and I_L = 20.5 mA (Per EA) until the brightness becomes ≤ 50% of its original value.

4.4 DISPLAY PORT INPUT SIGNAL TIMING SPECIFICATIONS

4.4.1 ELECTRICAL SPECIFICATIONS

Parameter	Symbol	Min.	Typ.	Max.	Unit	Notes
Differential Signal Common Mode Voltage(MainLink and AUX)	VCM	0		2	V	(1)(4)
AUX AC Coupling Capacitor	C_Aux_Source	75		200	nF	(2)
Main Link AC Coupling Capacitor	C_ML_Source	75		200	nF	(3)
DPCD Version (Address 00000h)	-	0x11h			-	(5)

Note (1) Display port interface related AC coupled signals should follow VESA DisplayPort Standard Version 1.

Revision 1a and VESA Embedded DisplayPort™ Standard Version 1.2. There are many optional items described in eDP1.2. If some optional item is requested, please contact us.

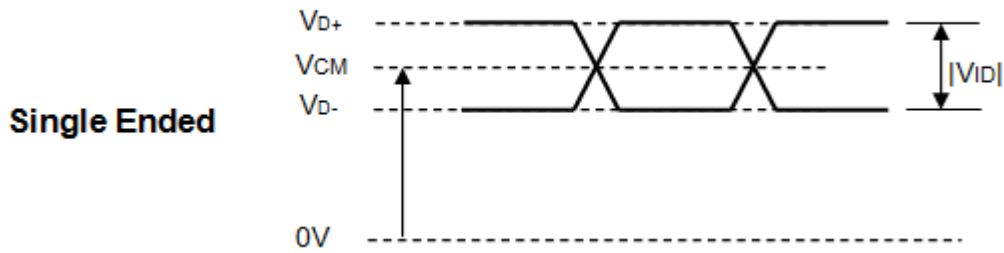

Note (2) Recommended eDP AUX Channel topology is as below and the AUX AC Coupling Capacitor (C_Aux_Source) should be placed on the source device.

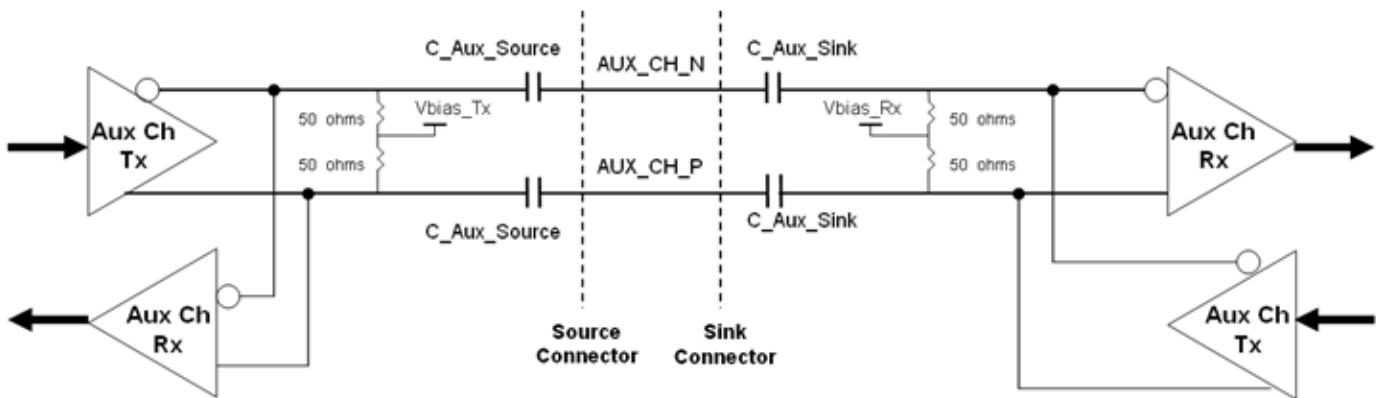

Note (3) Recommended Main Link Channel topology is as below and the Main Link AC Coupling Capacitor (C_ML_Source) should be placed on the source device.

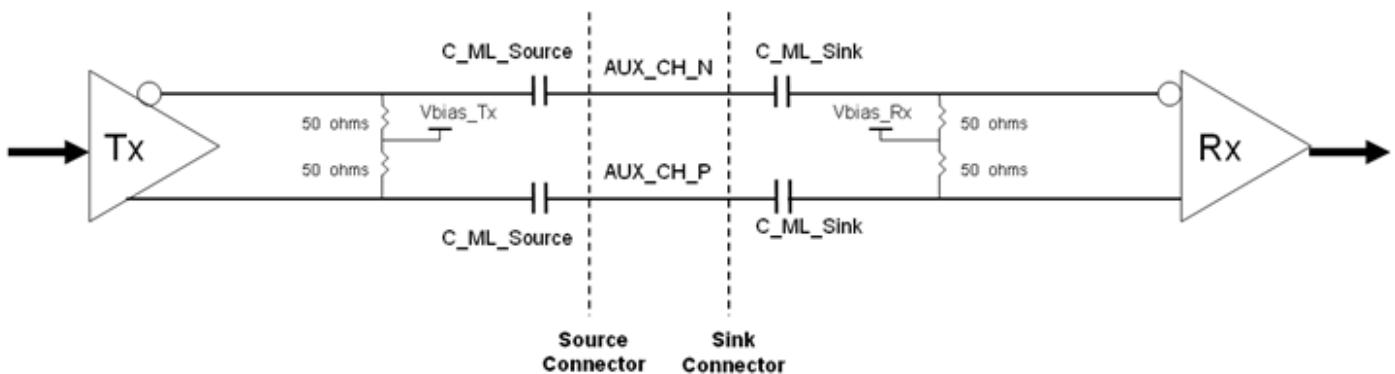

Note(4) The source device should pass the test criteria described in DisplayPortCompliance Test Specification (CTS) 1.1

4.4.2 COLOR DATA INPUT ASSIGNMENT

The brightness of each primary color (red, green and blue) is based on the 8-bit gray scale data input for the color. The higher the binary input the brighter the color. The table below provides the assignment of color versus data input.

Color		Data Signal																							
		Red								Green								Blue							
		R7	R6	R5	R4	R3	R2	R1	R0	G7	G6	G5	G4	G3	G2	G1	G0	B7	B6	B5	B4	B3	B2	B1	B0
Basic Colors	Black	0	0	0	0	0	0	0	0	0	0	0	0	0	0	0	0	0	0	0	0	0	0	0	
	Red	1	1	1	1	1	1	1	1	0	0	0	0	0	0	0	0	0	0	0	0	0	0	0	
	Green	0	0	0	0	0	0	0	0	1	1	1	1	1	1	1	1	0	0	0	0	0	0	0	
	Blue	0	0	0	0	0	0	0	0	0	0	0	0	0	0	0	1	1	1	1	1	1	1	1	
	Cyan	0	0	0	0	0	0	0	0	1	1	1	1	1	1	1	1	1	1	1	1	1	1	1	
	Magenta	1	1	1	1	1	1	1	1	0	0	0	0	0	0	0	0	1	1	1	1	1	1	1	
	Yellow	1	1	1	1	1	1	1	1	1	1	1	1	1	1	1	1	0	0	0	0	0	0	0	
	White	1	1	1	1	1	1	1	1	1	1	1	1	1	1	1	1	1	1	1	1	1	1	1	
Gray Scale Of Red	Red(0) / Dark	0	0	0	0	0	0	0	0	0	0	0	0	0	0	0	0	0	0	0	0	0	0		
	Red(1)	0	0	0	0	0	0	1	0	0	0	0	0	0	0	0	0	0	0	0	0	0	0		
	Red(2)	0	0	0	0	0	0	1	0	0	0	0	0	0	0	0	0	0	0	0	0	0	0		
	⋮	⋮	⋮	⋮	⋮	⋮	⋮	⋮	⋮	⋮	⋮	⋮	⋮	⋮	⋮	⋮	⋮	⋮	⋮	⋮	⋮	⋮			
	⋮	⋮	⋮	⋮	⋮	⋮	⋮	⋮	⋮	⋮	⋮	⋮	⋮	⋮	⋮	⋮	⋮	⋮	⋮	⋮	⋮	⋮			
	Red(253)	1	1	1	1	1	1	0	1	0	0	0	0	0	0	0	0	0	0	0	0	0	0		
	Red(254)	1	1	1	1	1	1	1	0	0	0	0	0	0	0	0	0	0	0	0	0	0	0		
	Red(255)	1	1	1	1	1	1	1	1	0	0	0	0	0	0	0	0	0	0	0	0	0	0		
Gray Scale Of Green	Green(0)/Dark	0	0	0	0	0	0	0	0	0	0	0	0	0	0	0	0	0	0	0	0	0	0		
	Green(1)	0	0	0	0	0	0	0	0	0	0	0	0	0	0	1	0	0	0	0	0	0	0		
	Green(2)	0	0	0	0	0	0	0	0	0	0	0	0	0	1	0	0	0	0	0	0	0	0		
	⋮	⋮	⋮	⋮	⋮	⋮	⋮	⋮	⋮	⋮	⋮	⋮	⋮	⋮	⋮	⋮	⋮	⋮	⋮	⋮	⋮	⋮			
	⋮	⋮	⋮	⋮	⋮	⋮	⋮	⋮	⋮	⋮	⋮	⋮	⋮	⋮	⋮	⋮	⋮	⋮	⋮	⋮	⋮	⋮			
	Green(253)	0	0	0	0	0	0	0	1	1	1	1	1	1	0	1	0	0	0	0	0	0	0		
	Green(254)	0	0	0	0	0	0	0	1	1	1	1	1	1	1	0	0	0	0	0	0	0	0		
Green(255)	0	0	0	0	0	0	0	1	1	1	1	1	1	1	1	0	0	0	0	0	0	0			
Gray Scale Of Blue	Blue(0) / Dark	0	0	0	0	0	0	0	0	0	0	0	0	0	0	0	0	0	0	0	0	0	0		
	Blue(1)	0	0	0	0	0	0	0	0	0	0	0	0	0	0	0	0	0	0	0	0	0	1		
	Blue(2)	0	0	0	0	0	0	0	0	0	0	0	0	0	0	0	0	0	0	0	0	1	0		
	⋮	⋮	⋮	⋮	⋮	⋮	⋮	⋮	⋮	⋮	⋮	⋮	⋮	⋮	⋮	⋮	⋮	⋮	⋮	⋮	⋮	⋮			
	⋮	⋮	⋮	⋮	⋮	⋮	⋮	⋮	⋮	⋮	⋮	⋮	⋮	⋮	⋮	⋮	⋮	⋮	⋮	⋮	⋮	⋮			
	Blue(253)	0	0	0	0	0	0	0	0	0	0	0	0	0	0	1	1	1	1	1	1	1	0		
	Blue(254)	0	0	0	0	0	0	0	0	0	0	0	0	0	0	1	1	1	1	1	1	1	0		
Blue(255)	0	0	0	0	0	0	0	0	0	0	0	0	0	0	1	1	1	1	1	1	1	1			

Note (1) 0: Low Level Voltage, 1: High Level Voltage

4.5 DISPLAY TIMING SPECIFICATIONS

The input signal timing specifications are shown as the following table and timing diagram.

Refresh Rate 60Hz

Signal	Item	Symbol	Min.	Typ.	Max.	Unit	Note
DCLK	Frequency	1/Tc	148.9	152.82	154.04	MHz	-
DE	Vertical Total Time	TV	1128	1132	1136	TH	-
	Vertical Active Display Period	TVD	1080	1080	1080	TH	-
	Vertical Active Blanking Period	TVB	TV-TVD	52	TV-TVD	TH	-
	Horizontal Total Time	TH	2200	2250	2260	Tc	-
	Horizontal Active Display Period	THD	1920	1920	1920	Tc	-
	Horizontal Active Blanking Period	THB	TH-THD	330	TH-THD	Tc	-

Note (1) The panel can operate at 60Hz normal mode and power saving mode, respectively. All reliability tests are based on specific timing of 60Hz refresh rate. We can only assure the panel's electrical function at power saving mode.

INPUT SIGNAL TIMING DIAGRAM

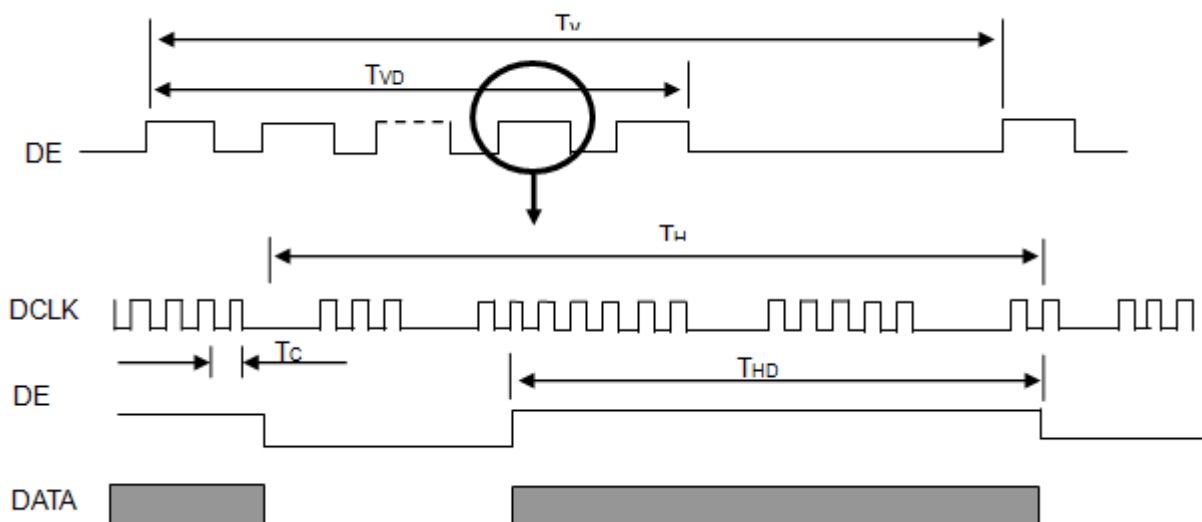

Note(2) The Input Signal must operate at eDP 2 lane.

Note(3) The $TV(=TVD+TVB)$ must be integer, otherwise, this module would operate abnormally

4.6 POWER ON/OFF SEQUENCE

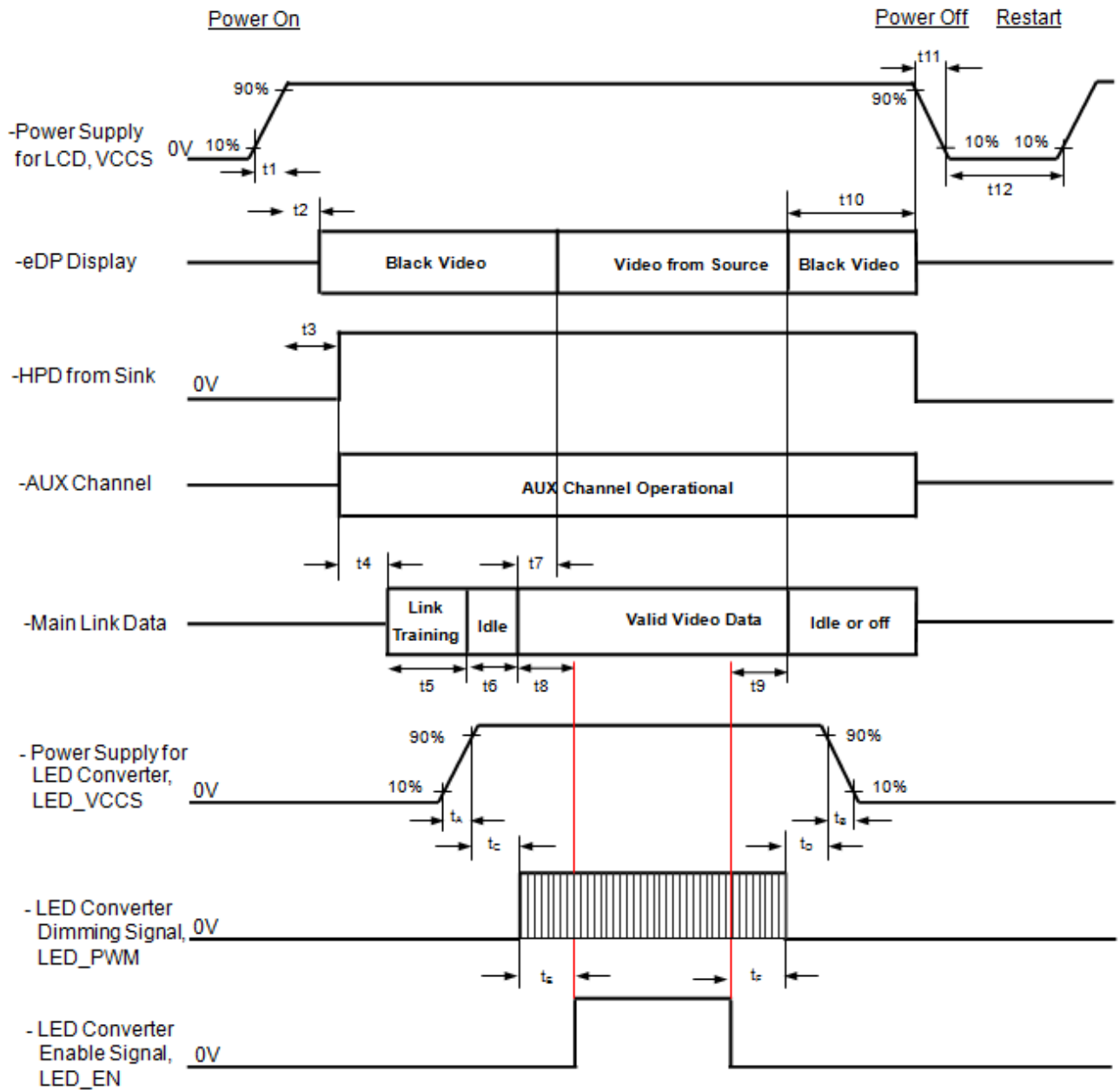

Timing Specifications

Parameter	Description	Reqd. By	Value		Unit	Notes
			Min	Max		
t1	Power rail rise time, 10% to 90%	Source	0.5	10	ms	-
t2	Delay from LCD,VCCS to black video generation	Sink	0	200	ms	Automatic Black Video generation prevents display noise until valid video data is received from the Source (see Notes:2 and 3 below)
t3	Delay from LCD,VCCS to HPD high	Sink	0	200	ms	Sink AUX Channel must be operational upon HPD high (see Note:4 below)
t4	Delay from HPD high to link training initialization	Source	0	-	ms	Allows for Source to read Link capability and initialize
t5	Link training duration	Source	0	-	ms	Dependant on Source link training protocol
t6	Link idle	Source	0	-	ms	Min Accounts for required BS-Idle pattern. Max allows for Source frame synchronization
t7	Delay from valid video data from Source to video on display	Sink	0	50	ms	Max value allows for Sink to validate video data and timing. At the end of T7, Sink will indicate the detection of valid video data by setting the SINK_STATUS bit to logic 1 (DPCD 00205h, bit 0), and Sink will no longer generate automatic Black Video
t8	Delay from valid video data from Source to backlight on	Source	80	-	ms	Source must assure display video is stable *: Recommended by INX. To avoid garbage image.
t9	Delay from backlight off to end of valid video data	Source	50	-	ms	Source must assure backlight is no longer illuminated. At the end of T9, Sink will indicate the detection of no valid video data by setting the SINK_STATUS bit to logic 0 (DPCD 00205h, bit 0), and Sink will automatically display Black Video. (See Notes: 2 and 3 below) *: Recommended by INX. To avoid garbage image.
t10	Delay from end of valid video data from Source to power off	Source	0	500	ms	Black video will be displayed after receiving idle or off signals from Source
t11	VCCS power rail fall time, 90% to 10%	Source	0.5	10	ms	-
t12	VCCS Power off time	Source	500	-	ms	-
tA	LED power rail rise time, 10% to 90%	Source	0.5	10	ms	-
tB	LED power rail fall time, 90% to 10%	Source	0	10	ms	-
tC	Delay from LED power rising to LED dimming signal	Source	1	-	ms	-
tD	Delay from LED dimming signal to LED power falling	Source	1	-	ms	-

tE	Delay from LED dimming signal to LED enable signal	Source	0	-	ms	-
tF	Delay from LED enable signal to LED dimming signal	Source	0	-	ms	-

Note (1) Please don't plug or unplug the interface cable when system is turned on.

Note (2) The Sink must include the ability to automatically generate Black Video autonomously. The Sink must automatically enable Black Video under the following conditions:

- Upon LCDVCC power-on (within T2 max)
- When the "NoVideoStream_Flag" (VB-ID Bit 3) is received from the Source (at the end of T9)

Note (3) The Sink may implement the ability to disable the automatic Black Video function, as described in Note (2), above, for system development and debugging purposes.

Note (4) The Sink must support AUX Channel polling by the Source immediately following LCDVCC power-on without causing damage to the Sink device (the Source can re-try if the Sink is not ready). The Sink must be able to response to an AUX Channel transaction with the time specified within T3 max.

5. OPTICAL CHARACTERISTICS

5.1 TEST CONDITIONS

Item	Symbol	Value	Unit
Ambient Temperature	Ta	25±2	°C
Ambient Humidity	Ha	50±10	%RH
Supply Voltage	According to typical value in "ELECTRICAL CHARACTERISTICS"		
Input Signal			
LED Light Bar Input Current Per Input Pin			

5.2 OPTICAL SPECIFICATIONS

The relative measurement methods of optical characteristics are shown in 5.2 and all items are measured at the center point of screen except white variation. The following items should be measured under the test conditions described in 5.1 and stable environment shown in Note (5).

Item	Symbol	Condition	Min.	Typ.	Max.	Unit	Note	
Color Chromaticity (CIE 1931)	Red	Rx	$\theta_x=0^\circ, \theta_y=0^\circ$ CS-2000 R=G=B=255 Gray scale	Typ – 0.03	0.648	Typ + 0.03	-	(1), (5)
		Ry			0.338			
	Green	Gx			0.313			
		Gy			0.600			
	Blue	Bx			0.153			
		By			0.050			
	White	Wx			0.305			
		Wy			0.340			
Color gamut	C.G		68	72	-	%	(7)	
Center Luminance of White	L _c		360	450	-	cd/m ²	(4), (5)	
Contrast Ratio	CR		700	1000	-	-	(2), (5)	
Response Time	T _R	$\theta_x=0^\circ, \theta_y=0^\circ$	-	14	19	ms	(3)	
	T _F		-	11	16			
White Variation	W	$\theta_x=0^\circ, \theta_y=0^\circ$	70	-	-	%	(5), (6)	
Viewing Angle	Horizontal	θ_{x+}	CR ≥ 10	80	89	-	Deg.	(1), (5)
		θ_{x-}		80	89	-		
	Vertical	θ_{y+}		80	89	-		
		θ_{y-}		80	89	-		

Note (1) Definition of Viewing Angle (θ_x , θ_y):

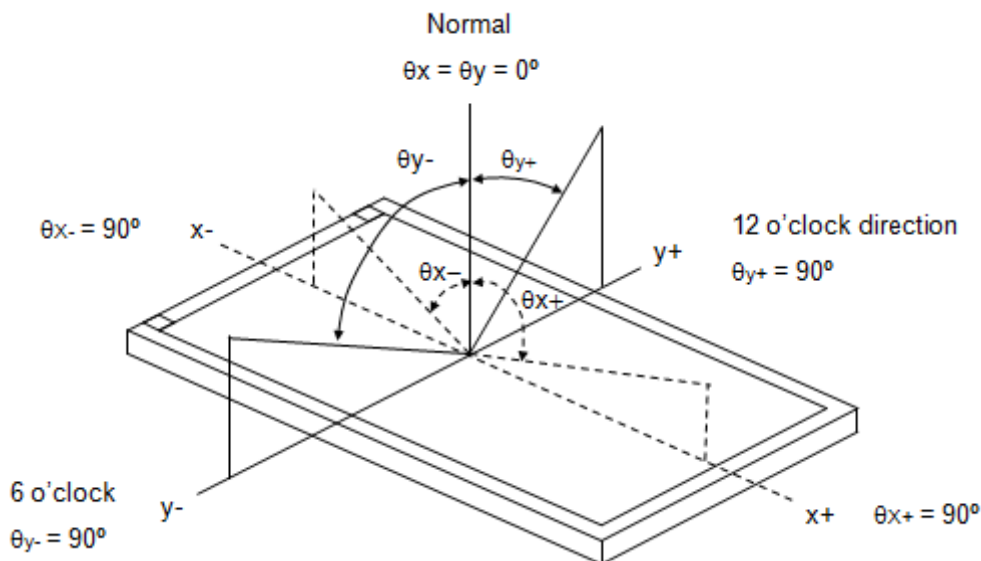

Note (2) Definition of Contrast Ratio (CR):

The contrast ratio can be calculated by the following expression.

$$\text{Contrast Ratio (CR)} = L_{63} / L_0$$

L₆₃: Luminance of gray level 63

L₀: Luminance of gray level 0

$$\text{CR} = \text{CR} (1)$$

CR (X) is corresponding to the Contrast Ratio of the point X at Figure in Note (6).

Note (3) Definition of Response Time (T_R , T_F):

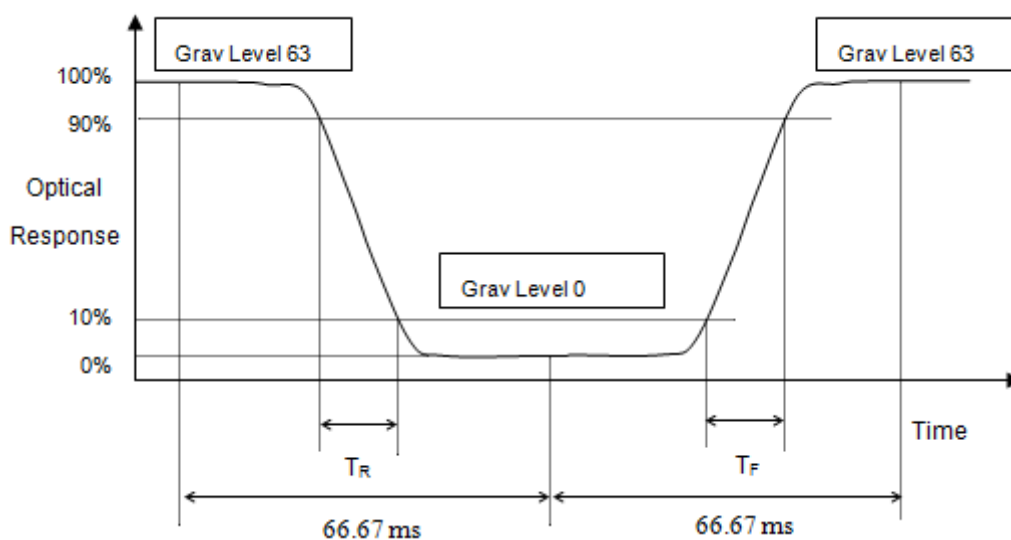

Note (4) Definition of Average Luminance of White (L_{AVE}):

Measure the luminance of gray level 63 at 5 points

$$L_{AVE} = [L (1) + L (2) + L (3) + L (4) + L (5)] / 5$$

L (x) is corresponding to the luminance of the point X at Figure in Note (6)

Note (5) Measurement Setup:

The LCD module should be stabilized at given temperature for 30 minutes to avoid abrupt temperature change during measuring. In order to stabilize the luminance, the measurement should be executed after lighting Backlight for 30 minutes in a windless room.

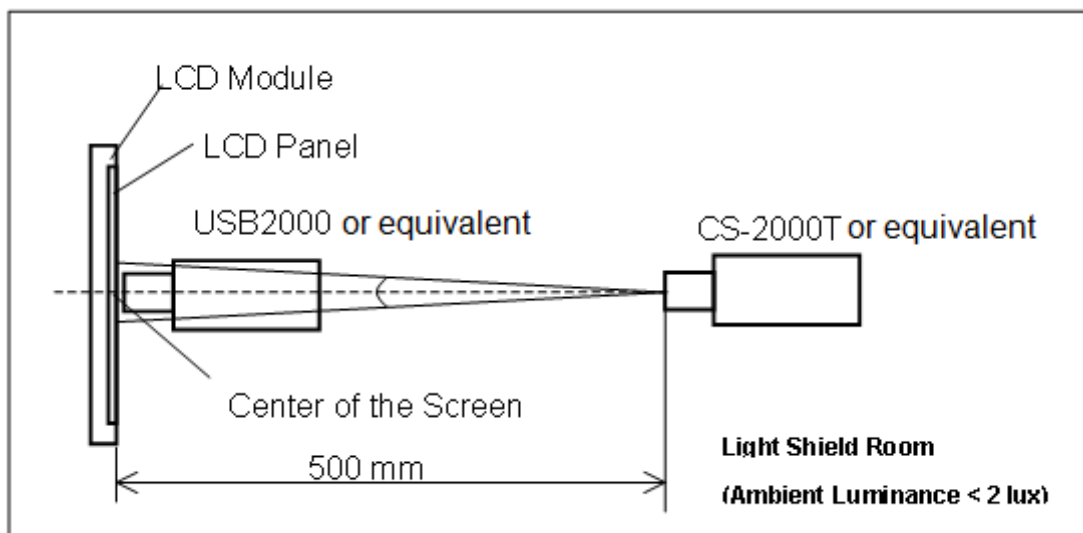

Note (6) Definition of White Variation (δW):

Measure the luminance of gray level 63 at 9 points

$$\delta W = (\text{Minimum} [L (1) \sim L (9)] / \text{Maximum} [L (1) \sim L (9)]) * 100\%$$

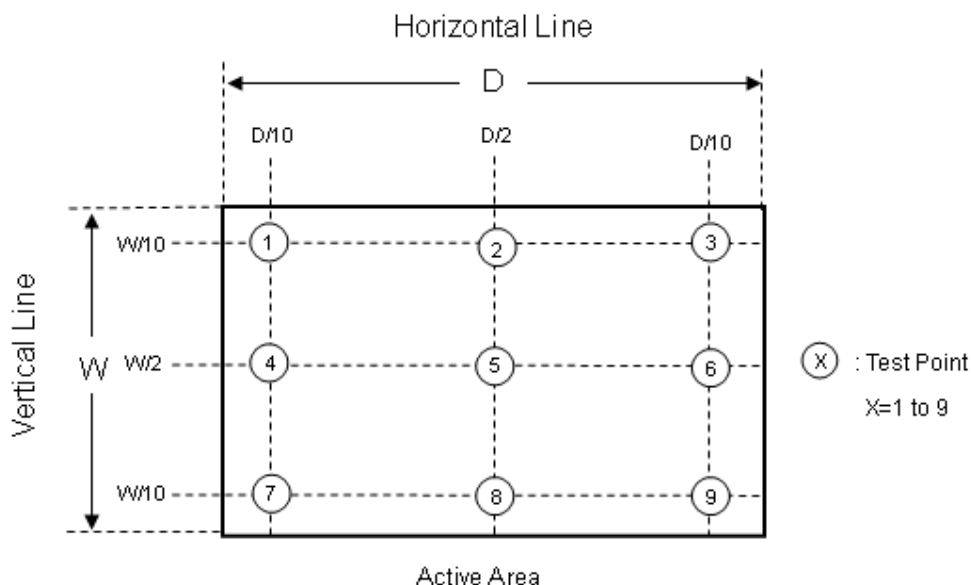

Note (7) Definition of color gamut (C.G%):

$$C.G\% = \frac{R G B}{R_0 G_0 B_0} \cdot 100\%$$

R_0, G_0, B_0 : color coordinates of red, green, and blue defined by NTSC, respectively.

R, G, B : color coordinates of module on 63 gray levels of red, green, and blue, respectively.

$R_0 G_0 B_0$: area of triangle defined by R_0, G_0, B_0

R G B: area of triangle

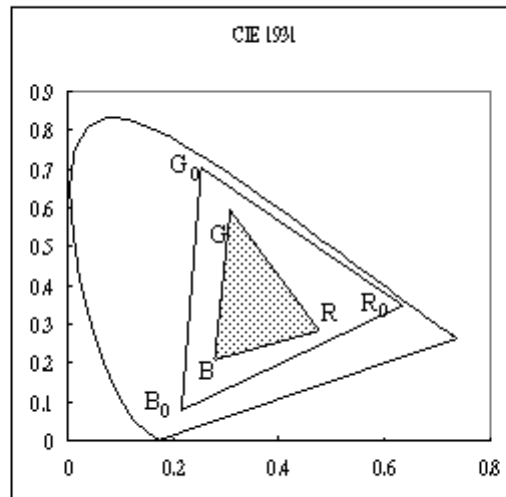

defined by R, G, B

6. RELIABILITY TEST ITEM

Test Item	Test Condition	Note
High Temperature Storage Test	70°C, 240 hours	(1)(2) (4)(5)
Low Temperature Storage Test	-20°C, 240 hours	
Thermal Shock Storage Test	-20°C, 0.5hour←-70°C, 0.5hour; 1hour/cycle,100cycles	
High Temperature Operation Test	60°C, 240 hours	
Low Temperature Operation Test	0°C, 240 hours	
High Temperature & High Humidity Operation Test	50°C, 80%RH, 240hours	(1)(2) (4)(6)
Shock (Non-Operating)	50G, 11ms, half sine wave, 1 time for ± X, ± Y, ± Z.	(2)(3)
Vibration (Non-Operating)	1.5G, 10 ~ 300 Hz, 10min/cycle, 3 cycles each X, Y, Z	(2)(3)

Note (1) There should be no condensation on the surface of panel during test.

Note (2) Temperature of panel display surface area should be 98 °C Max.

Note (3) At testing Vibration and Shock, the fixture in holding the module has to be hard and rigid enough so that the module would not be twisted or bent by the fixture.

Note (4) In the standard conditions, there is no function failure issue occurred. All the cosmetic specification is judged before reliability test.

Note (5) Before cosmetic and function test, the product must have enough recovery time, at least 2 hours at room temperature.

Note (6) Before cosmetic and function test, the product must have enough recovery time, at least 24 hours at room temperature.

7. PACKING

7.1 PACKING SPECIFICATIONS

- (1) 18 pcs LCD modules / 1 Box
- (2) Box dimensions: 490 (L) X 350 (W) X 320 (H) mm
- (3) Weight: approximately 16.3Kg (18 modules per box)

7.2 PACKING METHOD

- (1) Box Dimensions : 490(L)*350(W)*320(H)
- (2) 18 Module/Carton

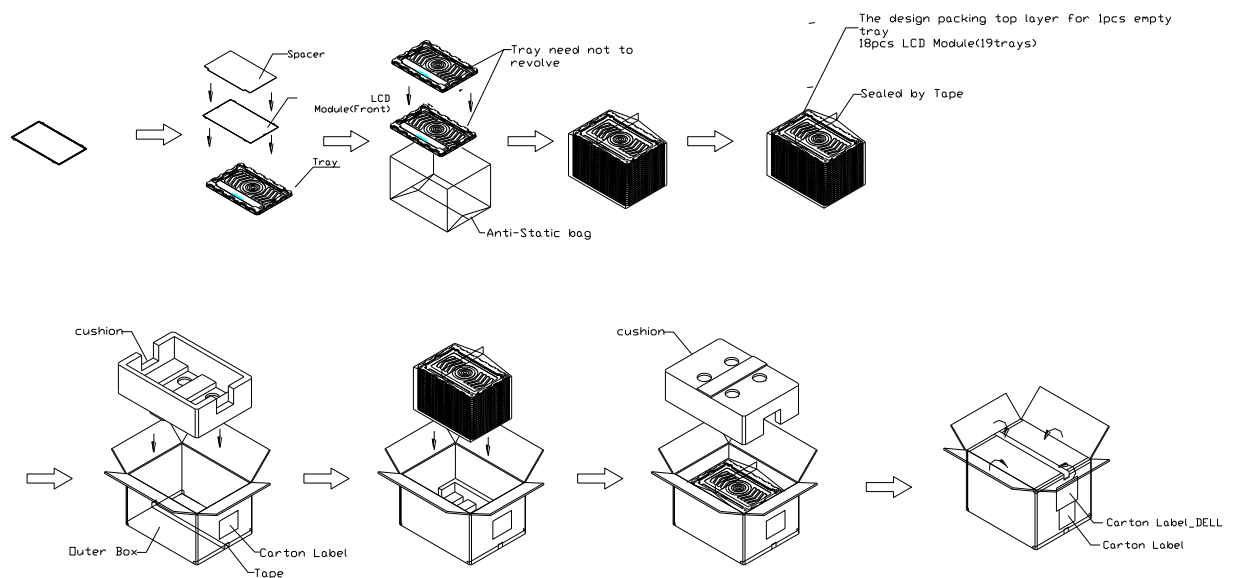

Figure. 7-2 Packing method

7.3 PALLET

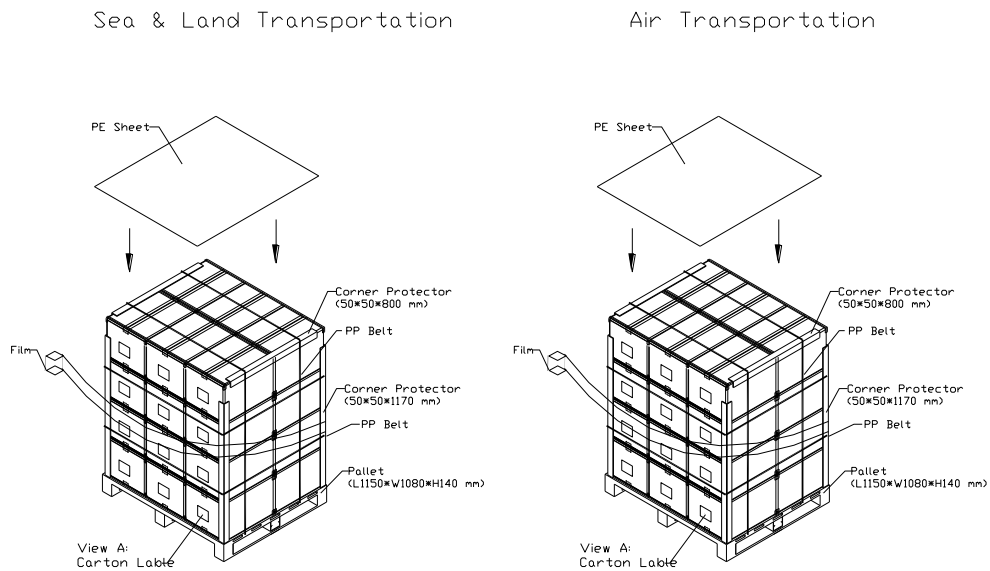

Figure. 7-3 Packing method

7.4 UN-PACK METHOD

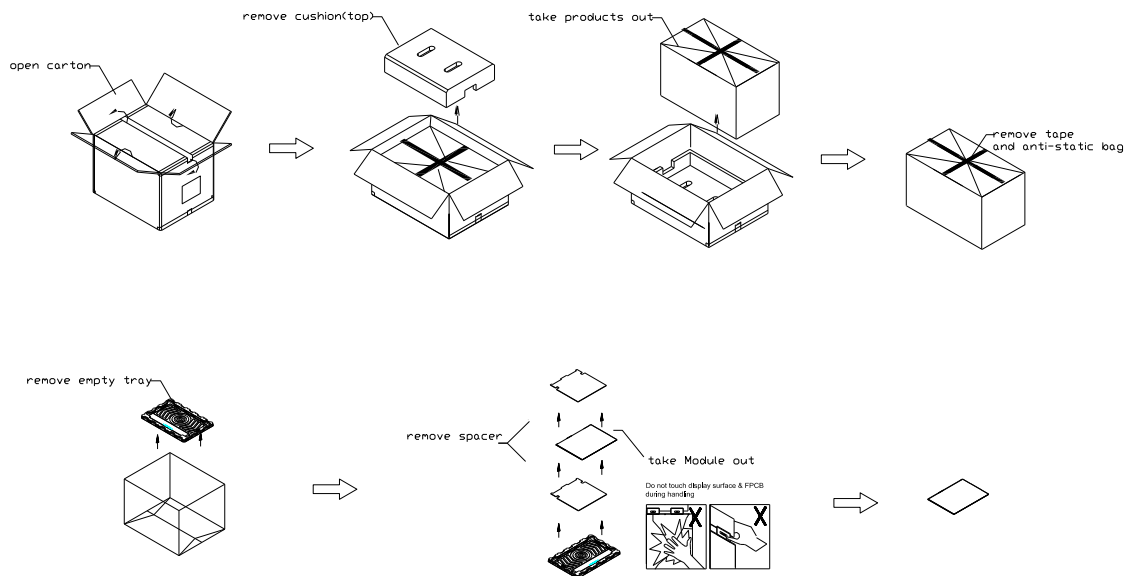
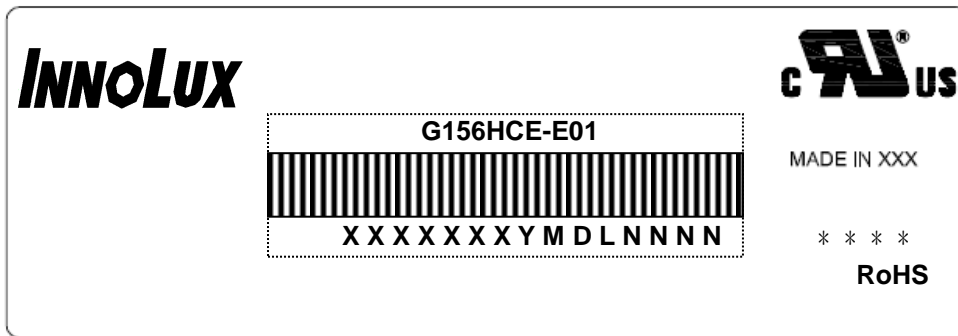

Figure. 7-4 Un-Packing method

8. MODULE LABEL

8.1 INX MODULE LABEL

The barcode nameplate is pasted on each module as illustration, and its definitions are as following explanation.



- (a) Model Name: G156HCE-E01
- (b) Revision: Rev. XX, for example: A1, B1, C1, C2 ...etc.
- (c) * * * * : Factory ID
- (d) Serial ID: XXXXXXXYMDXNNNN

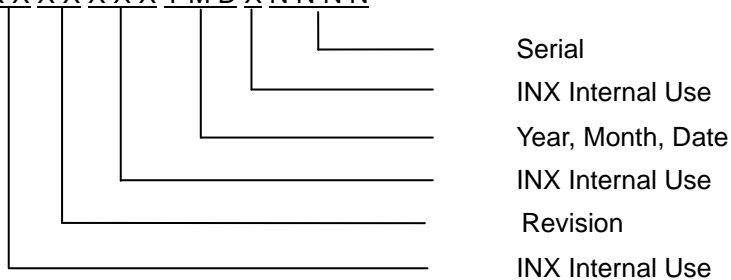

Serial ID includes the information as below:

- (a) Manufactured Date: Year: 0~9,...2019=9, 2020=0, 2021=1...,2028=8.
 Month: 1~12=1, 2, 3, ~, 9, A, B, C.
 Day: 1~31=1, 2, 3, ~, 9, A, B, C, ~, W, X, Y,, exclude I , O and U
- (b) Revision Code: cover all the change
- (c) Serial No.: Manufacturing sequence of product

9. PRECAUTIONS

9.1 ASSEMBLY AND HANDLING PRECAUTIONS

- (1) Do not apply rough force such as bending or twisting to the module during assembly.
- (2) To assemble or install module into user's system can be only in clean working areas. The dust and oil may cause electrical short or worsen the polarizer.
- (3) It's not permitted to have pressure or impulse on the module because the LCD panel and Backlight will be damaged.
- (4) Always follow the correct power sequence when LCD module is connecting and operating. This can prevent damage to the CMOS LSI chips during latch-up.
- (5) Do not pull the I/F connector in or out while the module is operating.
- (6) Do not disassemble the module.
- (7) Use a soft dry cloth without chemicals for cleaning, because the surface of polarizer is very soft and easily scratched.
- (8) It is dangerous that moisture come into or contacted the LCD module, because moisture may damage LCD module when it is operating.
- (9) High temperature or humidity may reduce the performance of module. Please store LCD module within the specified storage conditions.
- (10) When ambient temperature is lower than 10°C may reduce the display quality. For example, the response time will become slowly.

9.2 STORAGE PRECAUTIONS

- (1) Do not leave the module in high temperature, and high humidity for a long time. It is highly recommended to store the module with temperature from 0°C to 35°C and relative humidity of less than 70%
- (2) Do not store the TFT – LCD module in direct sunlight
- (3) The module should be stored in dark place. It is prohibited to apply sunlight or fluorescent light in storing

9.3 OPERATION PRECAUTIONS

- (1) The LCD product should be operated under normal condition.
Normal condition is defined as below :
Temperature : 20±15°C
Humidity: 65±20%
Display pattern : continually changing pattern(Not stationary)
- (2) If the product will be used in extreme conditions such as high temperature, high humidity, high altitude, display pattern or operation time etc... It is strongly recommended to contact CMI for application engineering advice. Otherwise, its reliability and function may not be guaranteed.

9.4 SAFETY PRECAUTIONS

- (1) If the liquid crystal material leaks from the panel, it should be kept away from the eyes or mouth. In case of contact with hands, skin or clothes, it has to be washed away thoroughly with soap.
- (2) After the module's end of life, it is not harmful in case of normal operation and storage.

9.5 SAFETY STANDARDS

The LCD module should be certified with safety regulations as follows:

- (1) UL60950-1 or updated standard.
- (2) IEC60950-1 or updated standard.

9.6 OTHER

When fixed patterns are displayed for a long time, remnant image is likely to occur

Appendix. OUTLINE DRAWING

