

HF36F

SUBMINIATURE INTERMEDIATE POWER RELAY



File No.:E134517



File No.:R50356442



File No.:CQC18002199981



Features

- 10A switching capability
- TV-5 125VAC approved by UL standard (only for 1 Form A)
- Plastic sealed and flux proofed types available
- 1 Form A and 1 Form C configurations

RoHS compliant

CONTACT DATA

Contact arrangement	1A, 1C
Contact resistance ¹⁾	100mΩ max.(at 1A 6VDC)
Contact material	AgSnO ₂ , AgCdO
Contact rating	10A 250VAC 10A 30VDC TV-5 125VAC
Max. switching voltage	250VAC / 30VDC
Max. switching current	10A
Max. switching power	2500VA / 300W
Mechanical endurance	1 x 10 ⁷ OPS
Electrical endurance	5 x 10 ⁴ OPS (10A 250VAC, Resistive load, Room temp., 1s on 9s off)

Notes: 1) The data shown above are initial values.

CHARACTERISTICS

Insulation resistance	1000MΩ (at 500VDC)
Dielectric strength	Between coil & contacts NO: 4000VAC 1min NC: 3000VAC 1min
	Between open contacts 1000VAC 1min
Operate time (at rated. volt.)	15ms max.
Release time (at rated. volt.)	5ms max.
Humidity	5% to 85% RH
Ambient temperature	-40°C to 70°C
Shock resistance	Functional 196m/s ²
	Destructive 980m/s ²
Vibration resistance	10Hz to 55Hz 1.5mm DA
Termination	PCB
Unit weight	Approx. 12g
Construction	Plastic sealed, Flux proofed

Notes: 1) The data shown above are initial values.

2) Please find coil temperature curve in the characteristic curves below.

3) UL insulation system: Class A.

COIL

Coil power	Standard: Approx. 530mW; Sensitive: Approx. 250mW
------------	--

COIL DATA

at 23°C

Standard type

Nominal Voltage VDC	Pick-up Voltage VDC max. ¹⁾	Drop-out Voltage VDC min. ¹⁾	Max. Voltage VDC *2)	Coil Resistance Ω
5	3.75	0.25	6.5	47 x (1±10%)
6	4.50	0.30	7.8	68 x (1±10%)
9	6.75	0.45	11.7	155 x (1±10%)
12	9.00	0.60	15.6	270 x (1±10%)
18	13.5	0.90	23.4	620 x (1±10%)
24	18.0	1.20	31.2	1080 x (1±10%)
48	36.0	2.40	62.4	4400 x (1±10%)

Sensitive type (Only for 1 Form A)

Nominal Voltage VDC	Pick-up Voltage VDC max. ¹⁾	Drop-out Voltage VDC min. ¹⁾	Max. Voltage VDC *2)	Coil Resistance Ω
5	3.75	0.25	6.5	100 x (1±10%)
6	4.50	0.30	7.8	145 x (1±10%)
9	6.75	0.45	11.7	325 x (1±10%)
12	9.00	0.60	15.6	575 x (1±10%)
18	13.5	0.90	23.4	1300 x (1±10%)
24	18.0	1.20	31.2	2310 x (1±10%)

Notes: 1) The data shown above are initial values.

2)*Maximum voltage refers to the maximum voltage which relay coil could endure in a short period of time.

SAFETY APPROVAL RATINGS

UL/CUL	1 Form C	10A 250VAC 10A 30VDC
	1 Form A	10A 250VAC 10A 30VDC TV-5 125VAC
TÜV		10A 250VAC COSØ =1 10A 30VDC L/R=0

Notes: 1) All values unspecified are at room temperature.

2) Only typical loads are listed above. Other load specifications can be available upon request.

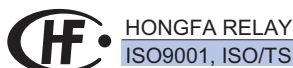

HONGFA RELAY

ISO9001, ISO/TS16949, ISO14001, OHSAS18001, IECQ QC 080000 CERTIFIED

2020 Rev. 1.01

ORDERING INFORMATION

Type	HF36F / 012 -H S L T (XXX)					
Coil voltage	5, 6, 9, 12, 18, 24, 48VDC					
Contact arrangement	H: 1 Form A		Z: 1 Form C			
Construction ¹⁾	S: Plastic sealed		Nil: Flux proofed			
Coil power	L: Sensitive (Only for 1 Form A)		Nil: Standard			
Contact material	T: AgSnO ₂		Nil: AgCdO			
Special code ³⁾	XXX: Customer special requirement			Nil: Standard		

Notes: 1) Under the ambience with dangerous gas like H₂S, SO₂ or NO₂, plastic sealed type is recommended; Please test the relay in real applications. If the ambience allows, flux proofed type is preferentially recommended.

2) Contact is recommended for suitable condition and specifications if water cleaning or surface process is involved in assembling relays on PCB.

3) The customer special requirement express as special code after evaluating by Hongfa.

OUTLINE DIMENSIONS, WIRING DIAGRAM AND PC BOARD LAYOUT

Unit: mm

Outline Dimensions

1 Form A & Flux proofed

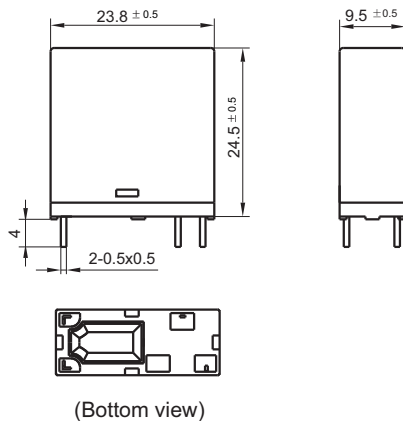

1 Form A & Plastic sealed

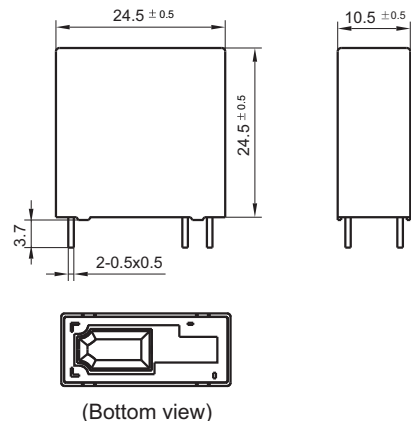

1 Form C & Flux proofed

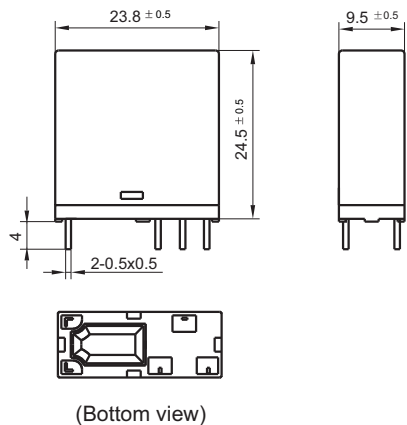

1 Form C & Plastic sealed

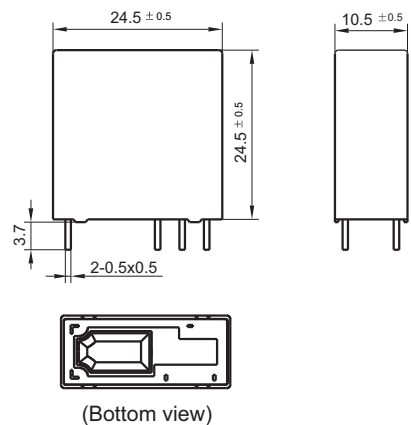

Wiring Diagram
(Bottom view)

1 Form A

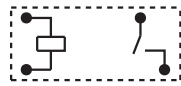

1 Form C

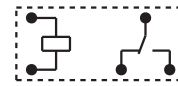

PCB Layout
(Bottom view)

1 Form A

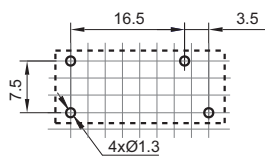

1 Form C

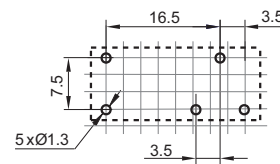

- Remark: 1) In case of no tolerance shown in outline dimension: outline dimension $\leq 1\text{mm}$, tolerance should be $\pm 0.2\text{mm}$; outline dimension $> 1\text{mm}$ and $\leq 5\text{mm}$, tolerance should be $\pm 0.3\text{mm}$; outline dimension $> 5\text{mm}$, tolerance should be $\pm 0.4\text{mm}$.
 2) The tolerance without indicating for PCB layout is always $\pm 0.1\text{mm}$.
 3) The width of the gridding is 2.5mm.

CHARACTERISTIC CURVES

ENDURANCE CURVE

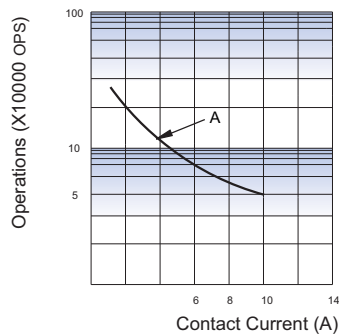

Notes:

- (1) Curve A: H type
- (2) Test conditions:
 10A 250VAC, Resistive load,
 Room temp., 1s on 9s off

COIL TEMPERATURE RISE

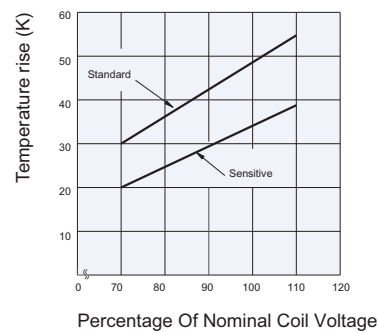

Disclaimer

The specification is for reference only. See to "Terminology and Guidelines" for more information. Specifications subject to change without notice. We could not evaluate all the performance and all the parameters for every possible application. Thus the user should be in a right position to choose the suitable product for their own application. If there is any query, please contact Hongfa for the technical service. However, it is the user's responsibility to determine which product should be used only.

© Xiamen Hongfa Electroacoustic Co., Ltd. All rights of Hongfa are reserved.