

# HF172F-140

# SOLAR RELAY



File No.: E133481



File No.: R50393829



### Features

- 140A switching capability
- Applicable to solar photovoltaic inverter
- 3.0 mm contact gap
- Low coil holding voltage contributes to saving energy of equipment
- UL insulation system: Class F

**RoHS compliant**

### CONTACT DATA

Contact arrangement	1A
Contact resistance(initial)	6mΩ max.(6VDC 20A)
Contact material	AgNi
Contact rating (Res. load)	Making 40A, carrying 140A breaking 40A, 400VAC at 85°C
Max. switching voltage	800VAC
Max. switching current	140A
Max. switching power	24000VA
Mechanical endurance	1 x 10 <sup>6</sup> OPS
Electrical endurance	3 x 10 <sup>4</sup> OPS (Making 40A, carrying 140A breaking 40A, at 85°C 1s on 9s off)

### COIL

Coil power	Approx. 2.5W
Holding voltage	40% to 100% U <sub>N</sub> (at 25°C) 50% to 60% U <sub>N</sub> (at 85°C)

**Notes:** 1) The coil holding voltage is the voltage applied to coil 100ms after the rated voltage.  
2) To avoid overheating and burning, the coil can not be consistently applied to with voltage larger than maximum holding voltage.

### SAFETY APPROVAL RATINGS

UL/CUL	Making 60A, carrying 140A breaking 60A, 277VAC at 85°C
	Making 40A, carrying 140A breaking 40A, 400VAC at 85°C
	Making 30A, carrying 140A breaking 30A, 800VAC at 85°C
TÜV	Making 60A, carrying 140A breaking 60A, 277VAC at 85°C
	Making 40A, carrying 140A breaking 40A, 400VAC at 85°C
	Making 30A, carrying 140A breaking 30A, 800VAC at 85°C

**Notes:** 1) All values unspecified are at room temperature.  
2) Only typical loads are listed above. Other load specifications can be available upon request.

### CHARACTERISTICS

Insulation resistance	1000MΩ (at 500VDC)	
Dielectric strength	Between open contacts	2000VAC 1min
	Between coil & contacts	5000VAC 1min
Surge Voltage	10kV(1.2 / 50μs)	
Operate time (at rated. volt.)	30ms max.	
Release time (at rated. volt.)	10ms max.	
Temperature rise	70K max. (Contact load current 140A, 50% to 60% rated voltage excitation, at 85°C)	
Shock resistance	Functional	98m/s <sup>2</sup>
	Destructive	980m/s <sup>2</sup>
Vibration resistance	10Hz to 55Hz 1.5mm DA	
Humidity	5% to 85% RH	
Ambient temperature	-40°C to 85°C (Apply holding voltage to coil)	
Termination	PCB	
Unit weight	Approx. 135g	
Construction	Flux proofed	

**Notes:** The data shown above are initial values.

### COIL DATA

at 23°C

Nominal Voltage VDC	Pick-up Voltage VDC max.	Drop-out Voltage VDC min.	Max. Voltage VDC *	Coil Resistance Ω
6	4.5	0.3	6.6	14.4 x (1±10%)
9	6.75	0.45	9.9	32.4 x (1±10%)
12	9	0.6	13.2	57.6 x (1±10%)
24	18	1.2	26.4	230.4 x (1±10%)

**Notes:** \*Maximun voltage refers to the maximum voltage which relay coil could endure in a short period of time.



HONGFA RELAY

ISO9001, ISO/TS16949, ISO14001, OHSAS18001, IECQ QC 080000 CERTIFIED

2019 Rev. 1.00

## ORDERING INFORMATION

Type	HF172F-140/	12	-H	F	(XXX)
Coil voltage	6, 9, 12, 24VDC				
Contact arrangement	H:1 Form A				
Insulation standard	F: Class F				
Special code <sup>3)</sup>	XXX: Customer special requirement		Nil: Standard		

- Notes:** 1) Flux-proofed relays can not be used in the environment with pollutants like H<sub>2</sub>S, SO<sub>2</sub>, NO<sub>2</sub>, dust, etc.  
 2) Water clearing or surface process is not suggested after the flux-proofed relays are assembled on PCB.  
 3) The customer special requirement express as special code after evaluating by Hongfa.

## OUTLINE DIMENSIONS, WIRING DIAGRAM AND PC BOARD LAYOUT

Unit: mm

Outline Dimensions

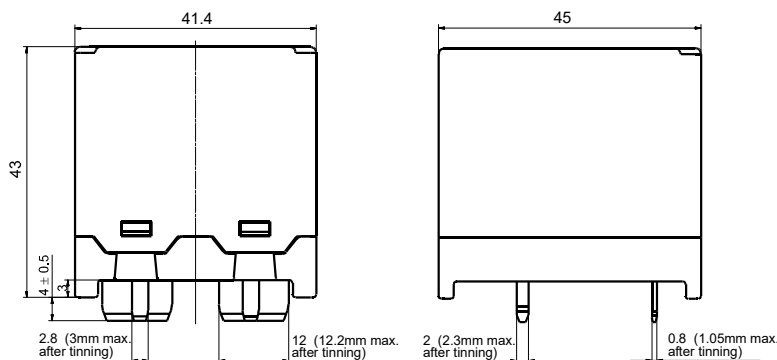

PCB Layout (Bottom view)

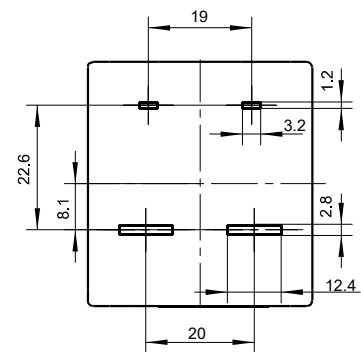

Wiring Diagram (Bottom view)

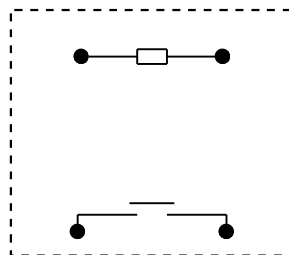

- Remark: 1) In case of no tolerance shown in outline dimension: outline dimension  $\leq 1$ mm, tolerance should be  $\pm 0.2$ mm; outline dimension  $> 1$ mm and  $\leq 5$ mm, tolerance should be  $\pm 0.3$ mm; outline dimension  $> 5$ mm, tolerance should be  $\pm 0.4$ mm.  
 2) The tolerance without indicating for PCB layout is always  $\pm 0.1$ mm.

### Disclaimer

The specification is for reference only. See to "Terminology and Guidelines" for more information. Specifications subject to change without notice. We could not evaluate all the performance and all the parameters for every possible application. Thus the user should be in a right position to choose the suitable product for their own application. If there is any query, please contact Hongfa for the technical service. However, it is the user's responsibility to determine which product should be used only.

© Xiamen Hongfa Electroacoustic Co., Ltd. All rights of Hongfa are reserved.